

And now for something completely different



And now for something completely different



# Algorithms for NLP (11-711)

## Fall 2016

Formal Language Theory  
In one lecture

Robert Frederking

# Now for Something Completely Different

- We will look at grammars from a “mathematical” point of view
- But Discrete Math (logic)
  - No real numbers
  - Symbolic discrete structures, proofs
- This is the source of many common algorithms/models
- Interested in complexity/power of different formal models of computation
  - Related to asymptotic complexity theory

# Two main classes of models

- Automata
  - Machines, like Finite-State Automata
- Grammars
  - Rule sets, like we have been using to parse
- We will look at each class of model, going from simpler to more complex/powerful
- We can formally prove complexity-class relations between these formal models

# Finite-State Automata (FSAs)

- Simplest formal automata
- We've seen these with numbers on them as HMMs, etc.

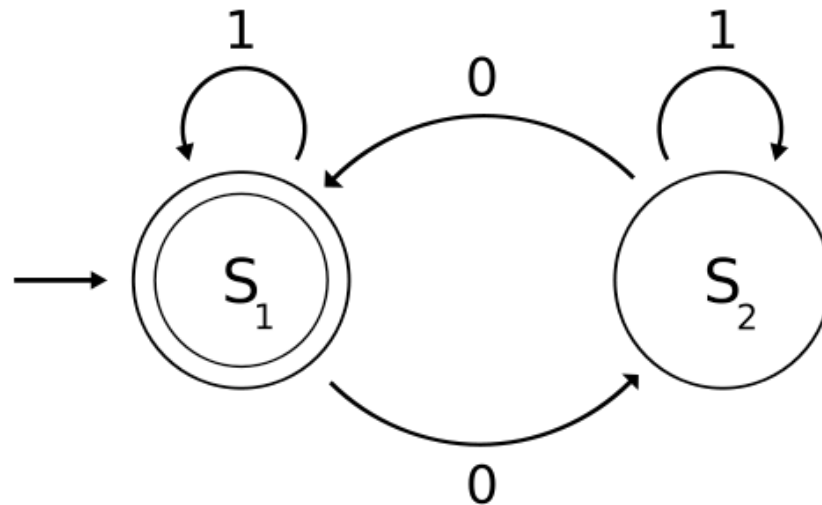

*(from Wikipedia)*

# Formal definition of automata

- A finite set of states,  $Q$
- A finite alphabet of input symbols,  $\Sigma$
- An initial (start) state,  $Q_0 \in Q$
- A set of final states,  $F_i \in Q$
- A transition function,  $\delta: Q \times \Sigma \rightarrow Q$
  
- This rigorously defines the FSAs we usually just draw as circles and arrows

# Formal Definition of a Grammar

- Vocabulary of terminal symbols,  $\Sigma$  (e.g.,  $a$ )
- Set of nonterminal symbols,  $N$  (e.g.,  $A$ )
- Special start symbol,  $S \in N$
- Production rules, such as  $A \rightarrow aB$ 
  - Restrictions on the rules determine what kind of grammar you have
- A formal grammar  $G$  defines a **formal language**, usually denoted  $L(G)$



# Regular Grammars

- Left-linear or right-linear grammars

- Left-linear template:

$$A \rightarrow Bx \text{ or } A \rightarrow x$$

- Right-linear template:

$$A \rightarrow xB \text{ or } A \rightarrow x$$

- Example:

$$S \rightarrow aA \mid bB \mid \varepsilon, \quad A \rightarrow aS, \quad B \rightarrow bbS$$

# Regular Expressions

- For this class, there's a simpler way to write expressions: regular expressions:

Terminal symbols

$(r + s)$

$(r \cdot s)$

$r^*$

$\varepsilon$

- For example:  $(aa+bbb)^*$

# Amazing fact #1: FSAs are equivalent to RGs

- Proof: two constructive proofs:
  - 1: given an arbitrary FSA, construct the corresponding Regular Grammar (and prove that it will only produce the strings the FSA would)
  - 2: given an arbitrary Regular Grammar, construct the corresponding FSA (and prove that it will only produce the strings the grammar would)

# DFSA, NDFSA

- Deterministic or Non-deterministic
  - Is  $\delta$  function ambiguous or not?

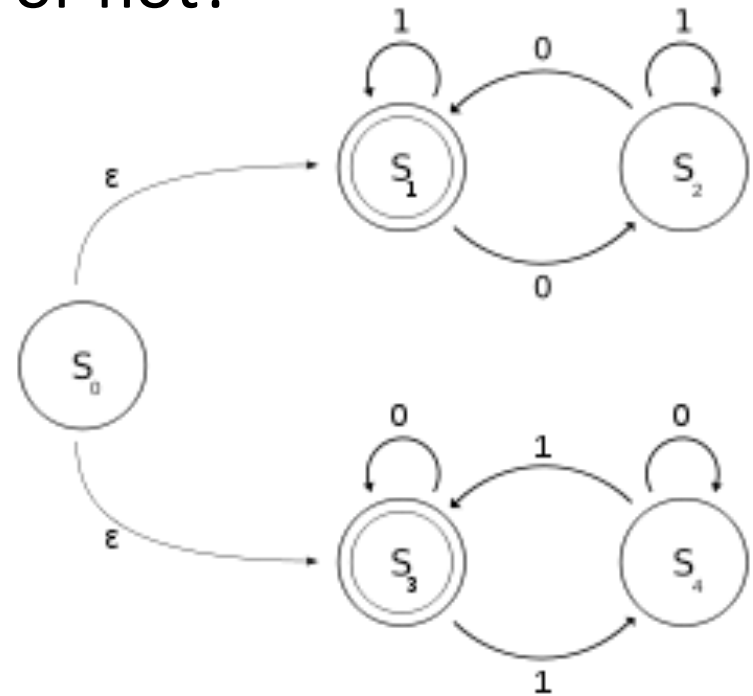

- For FSAs, weakly equivalent

# Intersecting, etc., FSAs

- We can investigate what happens after performing different operations on FSAs:
  - Union
  - Intersection
  - Concatenation
  - Negation
  - other operations: determinizing and minimizing FSAs

# Proving a language is *not* regular

- So, what kinds of languages are *not* regular?
- Informally, a FSA can only *remember* a finite number of *specific* things. So a language requiring an unbounded memory won't be regular.
- What about  $a^n b^n$ ?

# Pumping Lemma

- If  $L$  is an infinite regular language, then there are strings  $x$ ,  $y$ , and  $z$  such that  $y \neq \varepsilon$  and  $xy^n z \in L$ , for all  $n \geq 0$ .

# Pumping Lemma argument:

- Consider a machine with  $N$  states
- Now consider an input of length  $N$ ; since we started in  $Q_0$ , we will now be in the  $(N+1)$ st state visited
- There *must* be a loop: we had to visit at least 1 state twice; let  $x$  be the string up to the loop,  $y$  the part in the loop, and  $z$  after the loop
- So it must be okay to also have  $N$  copies of  $y$  (including 0 copies)



# Pumping Lemma: figure

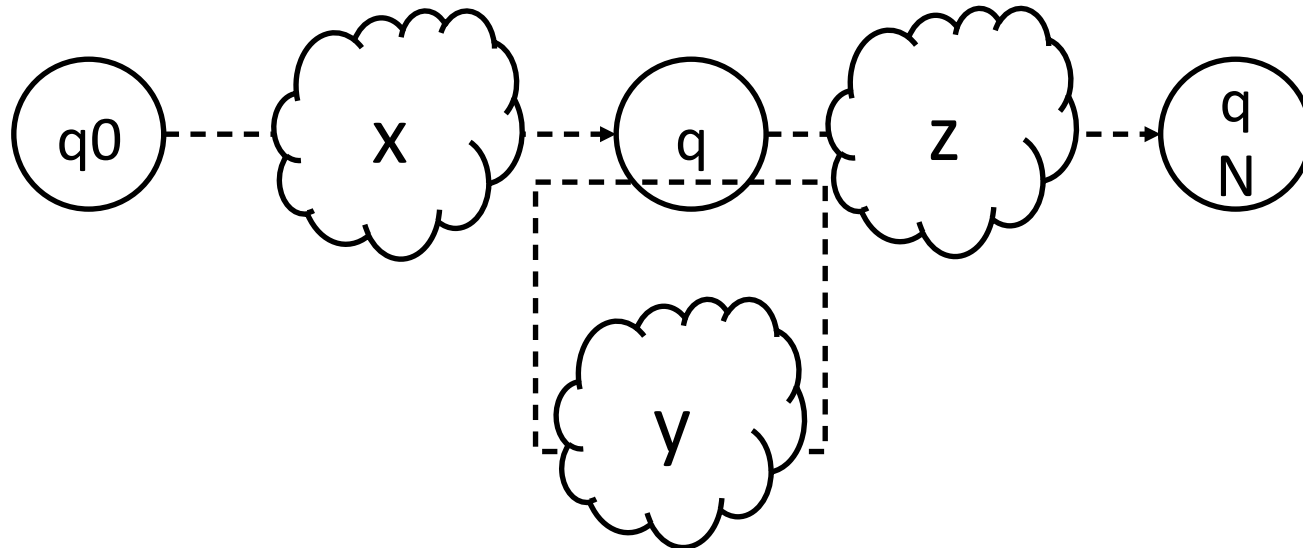

# Example proof that a L is not regular

- What about  $a^n b^n$ ?
- Three cases:
  - $y$  is only  $a$ 's: then  $xy^n z$  will have too many  $a$ 's
  - $y$  is only  $b$ 's: then  $xy^n z$  will have too many  $b$ 's
  - $y$  is a mix: then there will be interspersed  $a$ 's and  $b$ 's
- So  $a^n b^n$  cannot be regular, since it cannot be pumped

# Push-Down Automata (PDAs)

- Let's add some unbounded memory, but in a limited fashion
- So, add a stack:

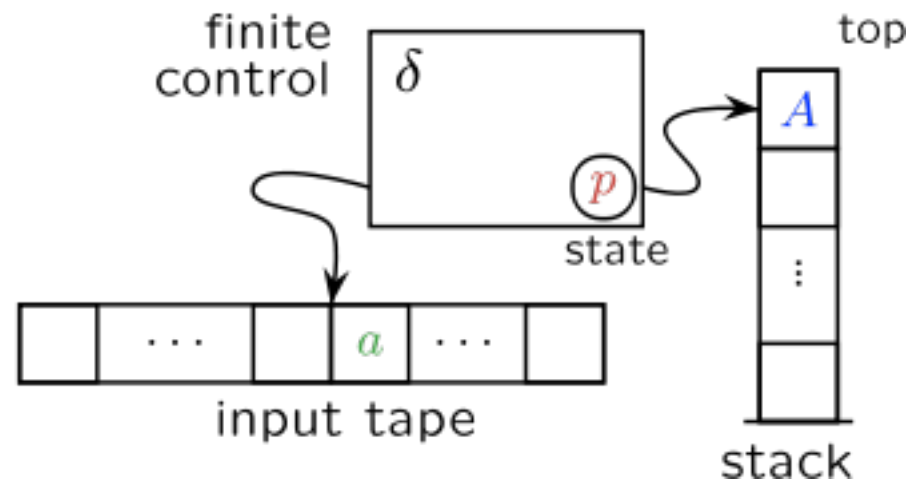

- Allows you to handle some non-regular languages, but not everything

# Context-Free Grammars

- Rule template:  
 $A \rightarrow \gamma$  where  $\gamma$  is any sequence of terminals/non-terminals
- Example:  $S \rightarrow a S b \mid \epsilon$
- We use these a lot in NLP.
  - Expressive enough, not too complex to parse.
    - We often add hacks to allow non-CF information flow.
  - It just feels like the right level of analysis.
    - (More on this later.)

# Amazing Fact #2: PDAs and CFGs are equivalent

- Same kind of proof as for FSAs and RGs, but more complicated
- Are there non-CF languages? How about  $a^n b^n c^n$ ?

# Turing Machines

- Just let the state move and write on the tape:

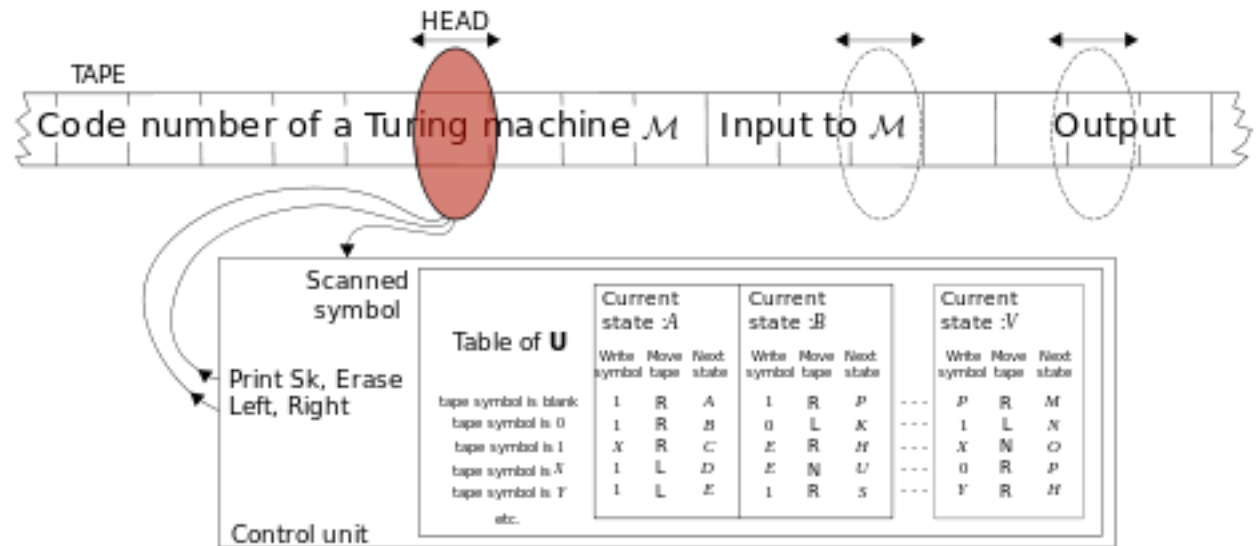

- This simple change produces general-purpose computer: Church-Turing Hypothesis

# TM made of LEGOs

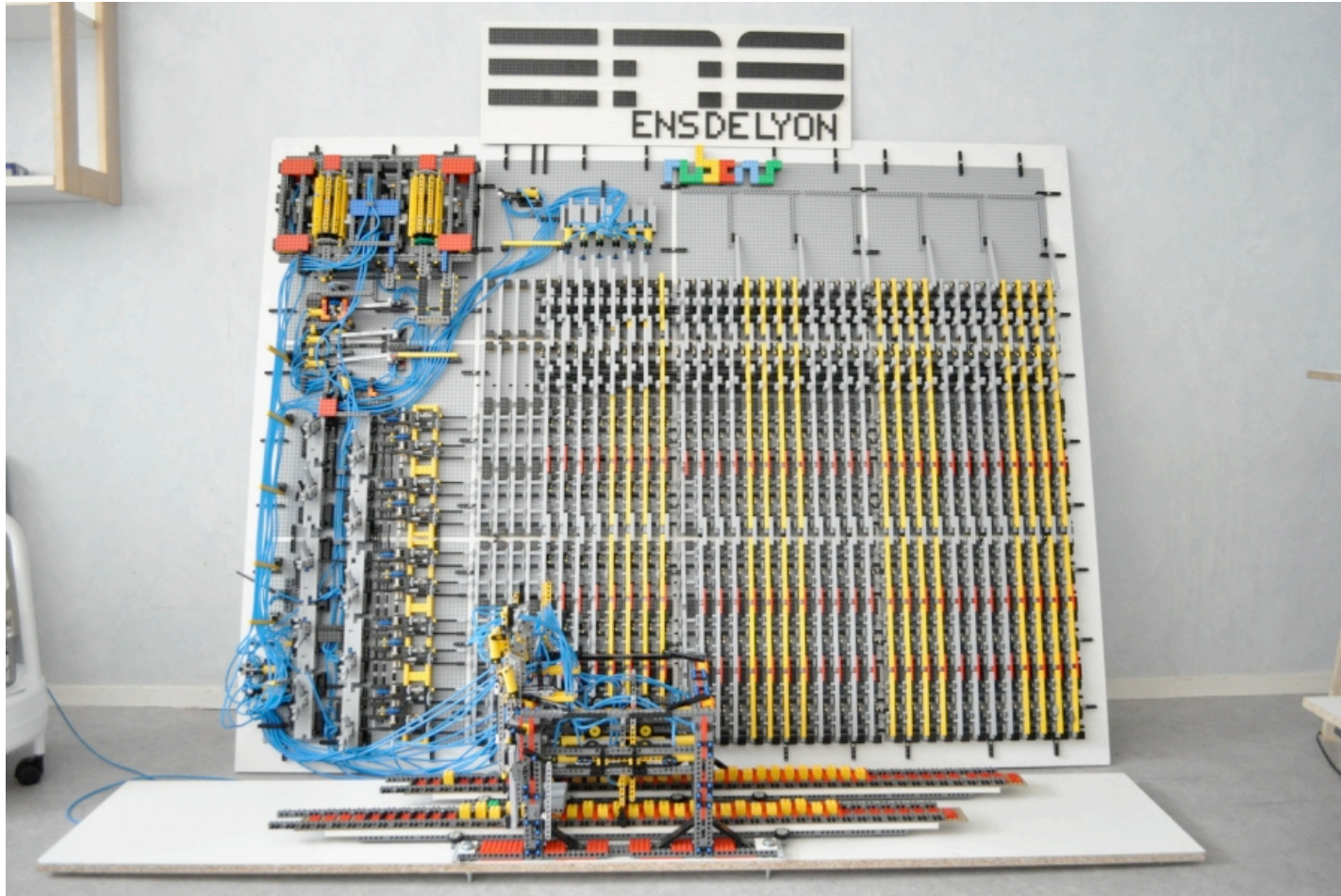

# Unrestricted Grammars

- $\alpha \rightarrow \beta$ , where each can be any sequence ( $\alpha$  not empty)
- Thus, there is *context* in the rules:
  - $aAb \rightarrow aab$
  - $bAb \rightarrow bbb$
- No surprise at this point: equivalent to TMs



# Linear-Bounded Automata/ Context-Sensitive Grammars

- TM that uses space linear in the input
- $\alpha A \beta \rightarrow \alpha \gamma \beta$  ( $\gamma$  not empty)
- We mostly ignore these; they get no respect
- Correspond to each other
- Limited compared to full-blown TM
  - But complexity can already be undecidable

# Even more amazing fact: Chomsky hierarchy

- Provable that each of these four classes is a proper subset of the next one:

Type 0: TM

Type 1: CSG

Type 2: CFG

Type 3: RE

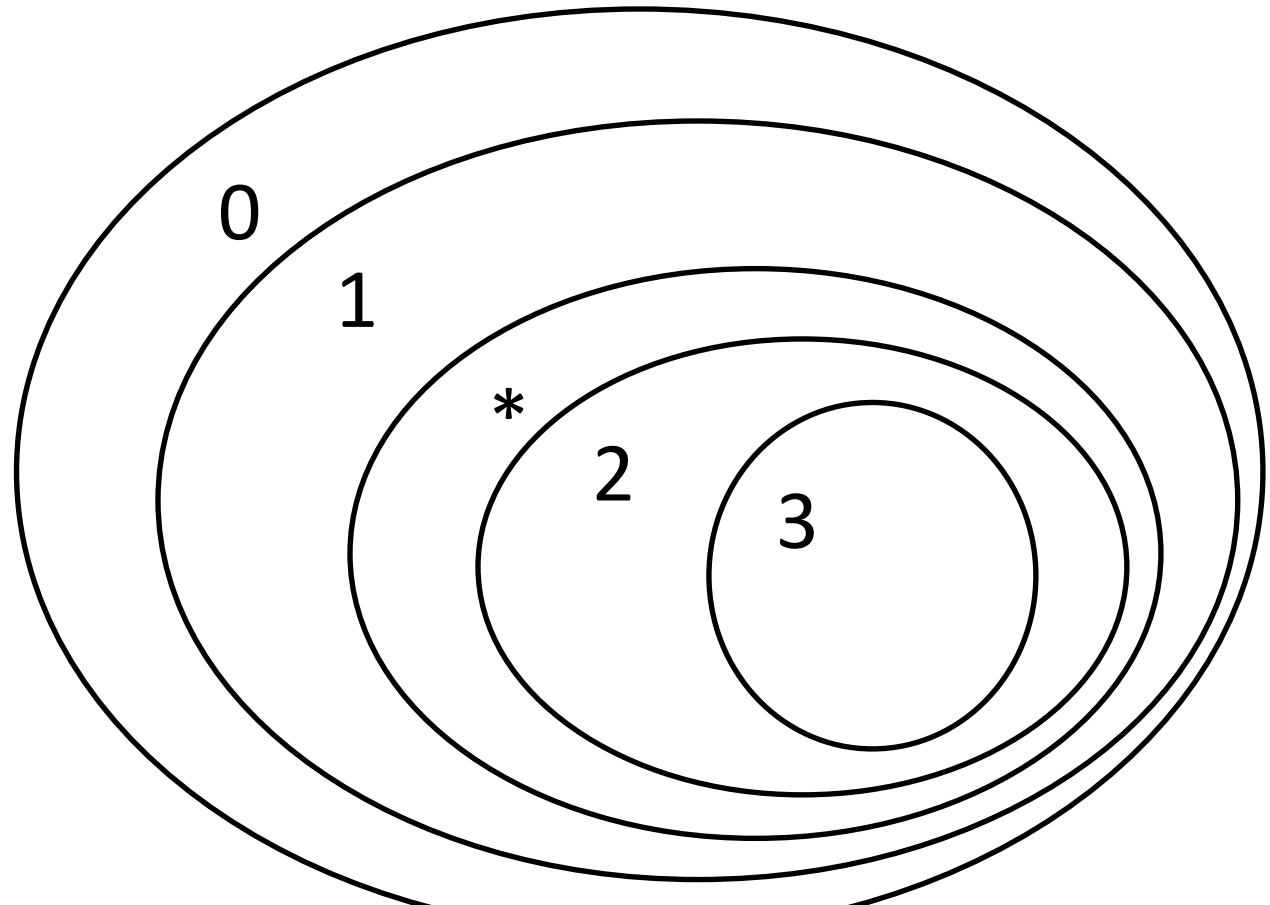

# Chomsky Hierarchy: proofs

- Form of hierarchy proofs:
  - For each class, you can prove there are languages not in the class, similar to Pumping Lemma proof
  - You can easily prove that the larger class really does contain all the ones in the smaller class

# Intersecting, etc., Ls

- We can again investigate what happens with Ls in these various classes under different operations on Ls:
  - Union
  - Intersection
  - Concatenation
  - Negation
  - other operations

# Chomsky hierarchy: table

| Type | Common Name              | Rule Skeleton  | Linguistic Example        |
|------|--------------------------|--|---------------------------|
| 0    | Turing Equivalent        | $\alpha \rightarrow \beta$ , s.t. $\alpha \neq \epsilon$                       | HPSG, LFG, Minimalism     |
| 1    | Context Sensitive        | $\alpha A \beta \rightarrow \alpha \gamma \beta$ , s.t. $\gamma \neq \epsilon$ |                           |
| –    | Mildly Context Sensitive |  | TAG, CCG                  |
| 2    | Context Free             | $A \rightarrow \gamma$   | Phrase-Structure Grammars |
| 3    | Regular                  | $A \rightarrow xB$ or $A \rightarrow x$  | Finite-State Automata     |

# Mildly Context-Sensitive Grammars

- We really like CFGs, but are they in fact expressive enough to capture all human grammar?
- Several non-hack extensions (CCG, TAG, etc.) turn out to be weakly equivalent!
  - “Mildly context sensitive”
- So CSFs get even less respect...
- And so much for the Chomsky Hierarchy being such a big deal

# Trying to prove human languages are *not* CF

- Certainly true of semantics. But NL syntax?
- Cross-serial dependencies seem like a good target:
  - *Mary, Jane, and Jim like red, green, and blue, respectively.*
  - But is this syntactic?
- Surprisingly hard to prove

# Swiss German dialect!

dative-NP accusative-NP dative-taking-VP accusative-taking-VP

- Jan säit das mer em Hans es huus hälfed aastriiche
- Jan says that we Hans the house helped paint
- “Jan says that we helped Hans paint the house”
  
- Jan säit das mer d’chind em Hans es huus haend wele laa hälfe aastriiche
- Jan says that we the children Hans the house have wanted to let help paint
- “Jan says that we have wanted to let the children help Hans paint the house”

(A little like “The cat the dog the mouse scared chased likes tuna fish”)



# Is Swiss German Context-Free?

Shieber's complex argument...

L1 =

Jan säit das mer (d'chind)\* (em Hans)\* es huus  
haend wele (laa)\* (hälfe)\* aastriche

L2 = Swiss German

L1  $\cap$  L2 =

Jan säit das mer (d'chind)<sup>n</sup> (em Hans)<sup>m</sup> es huus  
haend wele (laa)<sup>n</sup> (hälfe)<sup>m</sup> aastriche

# Why do we care?

- Math is fun?
- Complexity: if you can use a RE, don't use a CFG. Be careful with anything fancier than a CFG.
- Probably a source for future new algorithms
- Probably *not* how humans actually process NL
- Maybe doesn't matter as much for NLP now that we know about real numbers?
  - But we don't want your friends making fun of you



# Is Swiss German Context-Free?

L1 =

Jan säit das mer (d'chind)\* (em Hans)\* es huus  
haend wele (laa)\* (hälfe)\* aastriche

L2 = Swiss German

L1  $\cap$  L2 =

Jan säit das mer (d'chind)<sup>n</sup> (em Hans)<sup>m</sup> es huus  
haend wele (laa)<sup>n</sup> (hälfe)<sup>m</sup> aastriche

# Examples

- The cat likes tuna fish
- The cat the dog chased likes tuna fish
- The cat the dog the mouse scared chased likes tuna fish
- The cat the dog the mouse the elephant squashed scared
- chased likes tuna fish
- The cat the dog the mouse the elephant the