

# Which Part of the Heap is Useful? Improving Heap Liveness Analysis

Vini Kanvar\*

Indian Institute of Technology Bombay  
India  
vkanvar@gmail.com

Uday P. Khedker

Indian Institute of Technology Bombay  
India  
uday@cse.iitb.ac.in

## Abstract

With the growing sizes of data structures allocated in heap, understanding the actual use of heap memory is critically important for minimizing cache misses and reclaiming unused memory. A static analysis aimed at this is difficult because the heap locations are unnamed. Using allocation sites to name them creates very few distinctions making it difficult to identify allocated heap locations that are not used. Heap liveness analysis using access graphs solves this problem by (a) using a storeless model of heap memory by naming the locations with access paths, and (b) representing the unbounded sets of access paths (which are regular languages) as finite automata.

We improve the scalability and efficiency of heap liveness analysis, and reduce the amount of computed heap liveness information by using *deterministic automata* and by *minimizing the inclusion of aliased access paths* in the language. Practically, our field-, flow-, context-sensitive liveness analysis on SPEC CPU2006 benchmarks scales to 36 kLoC (existing analysis scales to 10.5 kLoC) and improves efficiency even up to 99%. For some of the benchmarks, our technique shows multifold reduction in the computed liveness information, ranging from 2 to 100 times (in terms of the number of live access paths), without compromising on soundness.

**Keywords:** liveness, heap, pointer, garbage collection

## 1 Introduction

Heap memory management is non-trivial and error-prone. Poorly written programs tend to run out of memory leading to failures. Heap liveness analysis identifies usages of heap locations. It can be used for identifying possible memory leaks, suggesting better use of stack in place of heap, identifying heap memory locations and links that can be reclaimed when they are not required any longer in a program, improving cache behaviour of programs etc.

\*Partially supported by a TCS fellowship

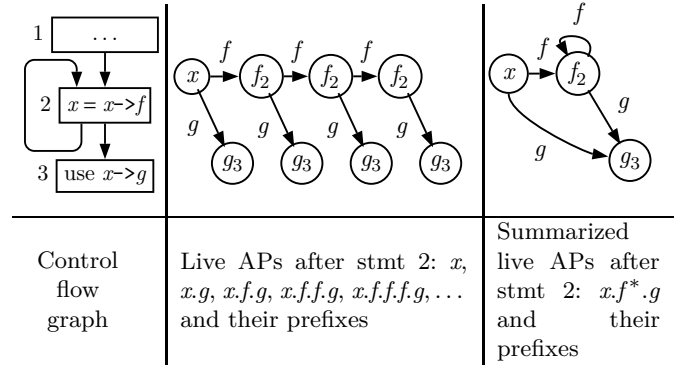

**Figure 1.** Summarization of infinite number of live access paths (APs) in the existing abstraction. Each node’s field label is same as its in-edge label.

Heap liveness information can be represented using a store-based model [6, 7] of memory by constructing a flow-sensitive *live points-to graph* [1]. At a given program point  $q$ , its nodes denote concrete memory locations and edges denote links between the locations such that the links are likely to be used before being re-defined along the control flow paths starting at  $q$ . For this model, a finite representation of live memory can be created by abstracting concrete heap locations using allocation-sites [2]. However, this is a very coarse representation because even large programs have a small number of allocation-sites (see our measurements for SPEC CPU2006 benchmarks in Figure 8). This makes very few distinctions between heap locations making it difficult to identify allocated heap locations that are not used.

A more precise representation of live heap can be constructed when it is viewed under a storeless model [6, 7] by naming locations in terms of *live access paths* [8] at each program point. An access path is a variable in  $V$  followed by a sequence of fields in  $F$ . Thus,  $V \times F^*$  represents the universal set of access paths. Variables and fields denote memory links. An access path is marked as live at program point  $q$ , if memory link(s) corresponding to its last field are likely to be used before being defined along some control flow path starting at  $q$ . For example, access path  $y$  in this abstraction indicates that variable  $y$  is dereferenced in

the program, and access path  $y.f.g$  suggests that the last field  $g$  is dereferenced from the location pointed to by field  $f$  of the location pointed to by variable  $y$ .

Due to loops and recursion, the set of access paths may be infinite and lengths of access paths may be unbounded. This warrants summarization. We ignore the adhoc summarization techniques such as  $k$ -limiting [7] (Section 7) and focus on *use-site* based summarization [8]: every use of a field name  $f \in F$  is labelled with a statement number  $s \in S$ ; the labelled fields and their statement numbers, represented as  $f_s$ , are treated as unique across the program across all access paths. This is illustrated below.

**Example 1.** Due to the presence of a loop in the program in Figure 1, field  $f$  appears an unbounded number of times in an access path rooted at variable  $x$ ; there is one occurrence of  $g$  after every occurrence of  $f$ . All these are represented as a graph whose nodes are labeled with fields and their use-sites,  $f_2$  and  $g_3$ . Nodes with the same label are merged to obtain a finite automaton, which precisely represents that the access paths denoted by regular expression  $x.f^*.g$  are live after statement 2.  $\square$

This abstraction has the following two limitations:

- In some cases, the resulting graph is imprecise in that it admits spurious access paths thereby over-approximating heap liveness.
- In some cases, the resulting graph is larger than the graph required to admit the same set of access paths.

Section 2 explains these limitations and our key ideas to overcome them. Sections 3 and 4 formalize our ideas. Section 5 describes how we lift our analysis to interprocedural level. Section 6 describes our implementations and measurements. Section 7 presents the related work. Section 8 concludes the paper. Appendix B proves soundness of the proposed heap liveness analysis. Appendix C identifies features in programs that show precision benefit (in terms of garbage collection of locations).

## 2 Our Key Ideas and Contributions

This section explains the limitations of the existing technique and how it can be improved. Let  $S$  denote the set of program statements (or sites).  $Q = \{\text{in}, \text{out}\} \times S$  is a set of program points. For statement  $s \in S$ ,  $\text{in}_s$  and  $\text{out}_s$  denote entry of  $s$  (i.e. program point immediately before  $s$ ) and exit of  $s$  (i.e. program point immediately after  $s$ ). For simplicity, we will assume that only heap locations have fields and the variables are not addressable. These assumptions are relaxed in Section 4.5.

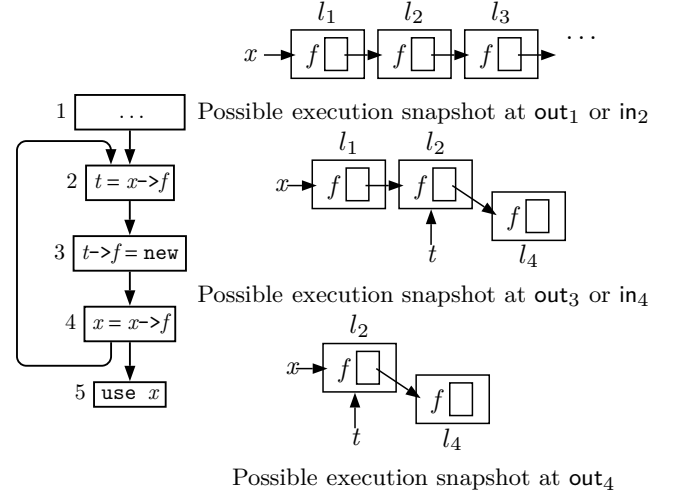

Point	Existing Non-Deterministic Graph	Proposed Deterministic Graph
$\text{in}_4$		
$\text{in}_2$		

**Figure 2.** Example. Execution snapshots and fixpoint computations of backward existing and proposed liveness analyses are shown. Each live node represents live access path(s) reaching it. Each node’s field label is same as its in-edge label. For simplicity, aliases of the access paths are not included. Step by step working is shown in Figure 13

The existing representation [8] of live access paths uses a non-deterministic automaton, which admits multiple transition sequences for a given access path. To represent each live access path by only one sequence of transitions, we propose to use a deterministic graph. Note that we do not merely create a deterministic version of the final non-deterministic graph but construct a deterministic graph in each step. This requires us to store *sets of use-sites* rather than a single use-site per field name. The example below illustrates that using sets of use-sites brings precision.

**Example 2.** Assume that the program in Figure 2 allocates heap locations in statement 1. At  $\text{in}_2$ , field  $f$  of location  $l_1$  is live because it will get used in statement 2. The rest of the links are dead because

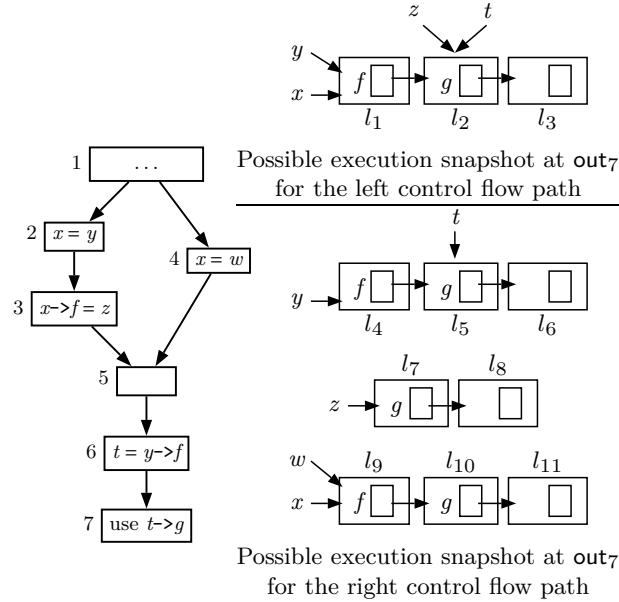

Point	Existing Greedy Liveness Analysis	Minimal Liveness Analysis	
		Phase 1	Phase 2
$\text{out}_7$	$\emptyset$	$\emptyset$	$\emptyset$
$\text{in}_6$	$\{y.f.g, y.f, y, x.f.g, x.f, w.f.g, w.f, z.g\}$	$\{y.f.g, y.f, y\}$	$\{y.f.g, y.f, y, x.f.g, x.f, z.g\}$
$\text{out}_4$	$\{y.f.g, y.f, y, x.f.g, x.f, w.f.g, w.f, z.g\}$	$\{y.f.g, y.f, y\}$	$\{y.f.g, y.f, y\}$
$\text{out}_3$	$\{y.f.g, y.f, y, x.f.g, x.f, w.f.g, w.f, z.g\}$	$\{y.f.g, y.f, y\}$	$\{y.f.g, y.f, y, x.f.g, x.f, z.g\}$
$\text{in}_3$	$\{y, x, z.g, z, w.f.g, w.f\}$	$\{y, x, z.g, z\}$	$\{y, x, z.g, z\}$

**Figure 3.** Example. A live access path represents that the memory link corresponding to its last field is live.

they are made unreachable in statement 3. The existing non-deterministic liveness graph in the row for  $\text{in}_2$ , denotes that the access paths  $x.f.f$  and its prefixes are live. This is spurious. Our proposed deterministic liveness graph in the row for  $\text{in}_2$  precisely shows that only  $x.f$  and its prefixes are live.  $\square$

For soundness, the existing technique includes aliases<sup>1</sup> of live access paths during backward liveness analysis. We call this approach *greedy liveness analysis* because it greedily includes all the aliases and propagates these in the backward analysis, irrespective

<sup>1</sup>The existing technique [8] includes alias closure. This introduces further over-approximation because may aliases are not transitive but the closure computation treats them as transitive.

of their need in the analysis of a statement. This backward propagation of live aliased access paths leads to imprecision. We propose to perform a two-phase analysis called *minimal liveness analysis*. Phase 1 uses aliases of live access paths minimally and phase 2 generates all aliases of live access paths without propagating them backwards in the control flow path. Below we illustrate how our minimal liveness analysis is more precise than greedy liveness analysis.

**Example 3.** In the program in Figure 3, statements 6 and 7 are equivalent to “use  $y \rightarrow f \rightarrow g$ ”. Therefore, using the snapshot of the right control flow path, we see that link  $f$  of location  $l_9$  and link  $g$  of location  $l_{10}$  are dead at  $\text{out}_4$  as they are not used in statements 5, 6, 7.

Existing analysis marks access path  $y.f.g$  and its prefixes as live at  $\text{in}_6$ . Since  $x$  and  $y$  are aliased, the existing greedy liveness analysis marks the aliases i.e.  $x.f.g$  and  $x.f$  also as live at  $\text{in}_6$ . These access paths are propagated backwards along the two control flow paths thereby imprecisely marking them as live at  $\text{out}_4$  also.

In phase 1 of our proposed analysis, access paths  $y.f.g$  and its prefixes are marked as live at  $\text{in}_6$ . However, their aliases, viz.  $x.f.g$  and  $x.f$  are not marked as live. Thus, when the live access paths are propagated backwards along the two control flow paths in phase 1, no spurious live access path gets propagated to  $\text{out}_4$ . Note that aliases are minimally used when statement 3 is analysed in order to treat LHS  $x \rightarrow f$  of the statement as  $y \rightarrow f$ . Phase 2 of our proposed analysis generates aliases  $x.f.g$  and  $x.f$  of live access paths at  $\text{in}_6$ . These are not propagated backwards in phase 2. At  $\text{out}_4$ , since  $y.f.g$  and its prefixes do not have any alias, no spurious liveness is generated at  $\text{out}_4$ .  $\square$

Our main contributions are: (i) showing how heap liveness information summarized with use-sites can be represented as a deterministic automaton (Section 3), (ii) showing how inclusion of aliases of live access paths can be minimized (Section 4), (iii) showing which heap liveness information can be bypassed from the callees and which can be memoized in the callee (Section 5). These improve scalability and efficiency of the analysis, and reduce the amount of computed liveness information of SPEC CPU2006.

### 3 Representations for Heap Liveness

A set of live access paths in the memory graph forms a regular language, represented as a finite automaton. Here, we describe two representations for storing heap live access paths and compare their precision using examples explained intuitively. Section 4 presents the formal details of computation of the representations.

To avoid handling of statements with multiple occurrences of the same field name, we normalize our

statements such that there is at most one field name in each statement. For example, statement “use  $y \rightarrow f \rightarrow f$ ” is normalized to  $t = y \rightarrow f$ ; use  $t \rightarrow f$ .

### 3.1 Existing Non-Deterministic Graph

Conventionally [8], the set of live access paths at program point  $q \in \mathbf{Q}$  is represented by a non-deterministic graph  $\hat{\mathbf{G}}_q = \langle \hat{\mathbf{V}}_q \cup \hat{\mathbf{N}}_q, \hat{\mathbf{E}}_q \rangle$ . Here node set  $\hat{\mathbf{V}}_q \cup \hat{\mathbf{N}}_q$  is a discriminated union of  $\hat{\mathbf{V}}_q \subseteq \mathbf{V}$ , which is a set of variables, and  $\hat{\mathbf{N}}_q$ , which is a set of field nodes, uniquely identified by a field and its use-site i.e.,  $\hat{\mathbf{N}}_q \subseteq \mathbf{F} \times \mathbf{S}$ . In other words, we identify each node with  $f_s$  where  $f \in \mathbf{F}$  and  $s \in \mathbf{S}$ .

Field nodes represented by the same  $f_s$  across access paths, or within an access path are merged at a program point. The intuition behind this merging is that fields with a common use-site are likely to be followed by the same sequences of fields. Hence their different occurrences across access paths, or within an access path, can be treated alike. In other words, access path construction can be assumed to reach the same state whenever a field node represented by a use-site is included in an access path. Hence,  $\hat{\mathbf{V}}_q$  and  $\hat{\mathbf{N}}_q$  represent states of the liveness graph (or automaton), which determines if access paths are accepted as live. For simplicity, we assume that all nodes in  $\hat{\mathbf{V}}_q \cup \hat{\mathbf{N}}_q$  are accepting states. Set  $\hat{\mathbf{V}}_q$  is a set of initial states of the automaton reachable by the variables in  $\hat{\mathbf{V}}_q$ .

Edge set  $\hat{\mathbf{E}}_q = \hat{\mathbf{E}}\hat{\mathbf{V}}_q \cup \hat{\mathbf{E}}\hat{\mathbf{F}}_q$  is a discriminated union of

- $\hat{\mathbf{E}}\hat{\mathbf{V}}_q \subseteq \hat{\mathbf{V}}_q \times \hat{\mathbf{N}}_q$  which is a set of edges from variables in  $\hat{\mathbf{V}}_q$
- $\hat{\mathbf{E}}\hat{\mathbf{F}}_q \subseteq \hat{\mathbf{N}}_q \times \mathbf{F} \times \hat{\mathbf{N}}_q$  which is a set of edges from nodes in  $\hat{\mathbf{N}}_q$  labeled with fields in  $\mathbf{F}$ .

Below we illustrate how the existing abstraction may generate spurious cycles in the liveness graph.

**Example 4.** At  $\text{in}_4$  of the program in Figure 2, links  $f$  of only locations  $l_1$  and  $l_2$  are live. Here the first link will be used by statement 4, and the second link will possibly be used by statements 2 and 4 of next loop iteration. Thus, only access path  $x.f.f$  and its prefixes are live at  $\text{in}_4$ .

Observe that, even though both  $f$  of  $l_1$  and  $f$  of  $l_2$  will be used by statement 4,  $f$  of  $l_2$  will additionally be used by statement 2 followed by killing of the field after  $f$  of  $l_2$  via variable  $t$  in statement 3. Basically, the two links corresponding to field  $f$  go through different changes and are followed by different sequences of fields because they are used by different statements. In spite of this, the existing technique merges the two corresponding field nodes identified as  $f_4$  in its non-deterministic representation thereby creating a

spurious cycle around the field node  $f_4$  (as shown in the row corresponding to  $\text{in}_4$ ). This spuriously indicates that infinite number of fields are live at  $\text{in}_4$ .  $\square$

The example below illustrates how the existing abstraction causes imprecise merging of access paths in a program even without loops.

**Example 5.** In the program in Figure 4, statements 5 and 6 are equivalent to “use  $x \rightarrow f \rightarrow g$ ”. Thus, at  $\text{in}_5$ , access path  $x.f.g$  and its prefixes are live. Its existing abstraction is shown in the row corresponding to  $\text{in}_5$  where nodes pointed to by  $f$  and  $g$  are identified as  $f_5$  and  $g_6$ . Statements 3 and 4 are equivalent to “ $x \rightarrow f \rightarrow g = \text{new}$ ”. Thus, at  $\text{in}_3$ ,  $x.f.g$  is dead. Since  $x.f$  and its prefixes are live at  $\text{out}_2$ , access path  $x.h.f$  and its prefixes are live at  $\text{in}_2$ . Overall, at  $\text{out}_1$ ,  $x.f.g$  from the left control flow path and  $x.h.f$  from the right control flow path are live.

Its existing abstraction is shown in the row corresponding to  $\text{out}_1$ . Here node pointed to by  $h$  is identified as  $h_2$ , node pointed to by  $f$  along  $x.f.g$  is identified as  $f_3$ , and nodes pointed to by  $f$  along  $x.h.f$  are identified as  $f_3$  and  $f_5$  in the non-deterministic graph because at  $\text{out}_1$ , link  $f$  of  $l_1$  (i.e. along  $x.f.g$ ) will be used by statement 5 and link  $f$  of  $l_5$  (i.e. along  $x.h.f$ ) will be used by both statements 3 and 5. Here statement 3 leads to killing of field after  $f$  of  $l_5$ . Basically,  $f$  of  $l_1$  and  $l_2$  go through different changes and are followed by different sequences of fields since they are used by different statements. In spite of this, the existing technique merges the corresponding two field nodes  $f_5$  (along  $x.h.f$  and  $x.f.g$ ) thereby creating a spurious access path  $x.h.f.g$  at  $\text{out}_1$ .  $\square$

Examples 4 and 5 show that applying use-sites may lead to spurious cycles and spurious access paths. This happens because the merged nodes do not necessarily have the same sequences of fields following them even though their use-site is identical. The non-deterministic representation does not account for all possible set of use-sites of a field while merging field nodes. This brings us to our proposed abstraction which labels field nodes with the set of all use-sites rather than a single use-site.

### 3.2 Proposed Deterministic Graph

We represent a set of live access paths at program point  $q \in \mathbf{Q}$  as a deterministic graph  $\mathbf{G}_q = \langle \mathbf{V}_q \cup \mathbf{N}_q, \mathbf{E}_q \rangle$ . Here node set  $\mathbf{V}_q \cup \mathbf{N}_q$  is a discriminated union of  $\mathbf{V}_q \subseteq \mathbf{V}$ , which is a set of variables, and  $\mathbf{N}_q$ , which is a set of field nodes, uniquely identified by a field and its set of use-sites i.e.,  $\mathbf{N}_q \subseteq \mathbf{F} \times 2^{\mathbf{S}}$ . In other words, we identify each node with  $f_\tau$  where  $f \in \mathbf{F}$  and  $\tau \subseteq \mathbf{S}$ .

Field nodes are merged if and only if they are represented by the same  $f_\tau$  across access paths, or

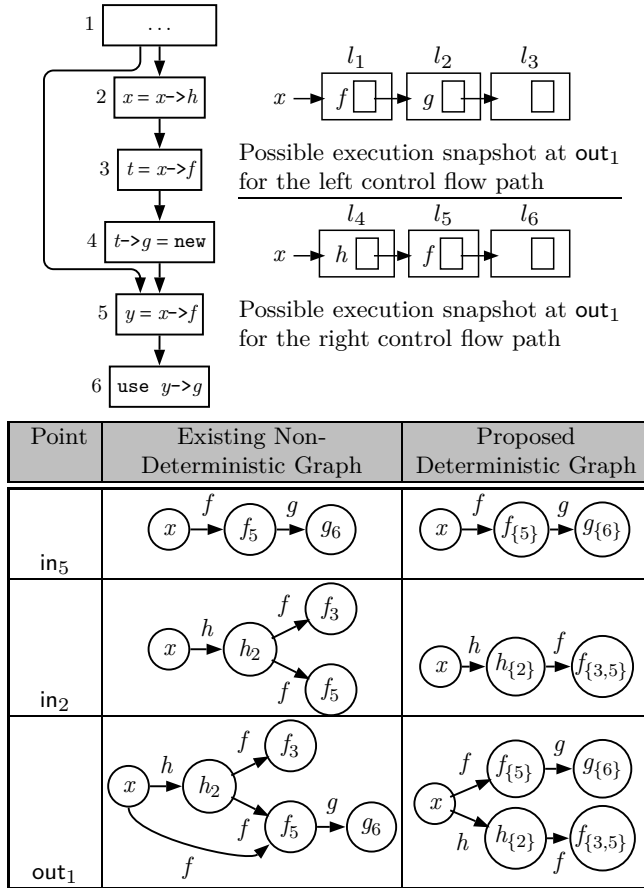

**Figure 4.** Example. Each node represents live access path(s) reaching it. For simplicity, aliases of the access paths are not included. Each node’s field label is same as its in-edge label.

within an access path at a program point. Like the existing representation, all nodes in  $V_q \cup N_q$  are assumed to be accepting states. Set  $V_q$  is a set of initial states of the automaton reachable by the variables in  $V_q$ .

Edge set  $E_q = EV_q \cup EF_q$  is a discriminated union of

- $EV_q : V_q \rightarrow N_q$  which is a set of edges from variables in  $V_q$
- $EF_q : N_q \times F \rightarrow N_q$  which is a set of edges from nodes in  $N_q$  labeled with fields in  $F$ .

The example below illustrates how the proposed abstraction improves summarization.

**Example 6.** For the program in Figure 2, at in<sub>4</sub>, access path  $x.f.f$  and its prefixes are live.  $f$  of  $l_1$  will be used by statement 4 and  $f$  of  $l_2$  will be used by statements 2 and 4. The proposed abstraction of  $x.f.f$  is shown in the row corresponding to in<sub>4</sub>. The two nodes  $f_{\{4\}}$  and  $f_{\{2,4\}}$  are not merged because their sets of use-sites are different

thereby improving the precision of liveness information as compared to the existing abstraction.  $\square$

The example below illustrates how the proposed abstraction improves merging of access paths.

**Example 7.** In the program in Figure 4, statements 5 and 6 are equivalent to “use  $x->f->g$ ”. Thus, at in<sub>5</sub>, access path  $x.f.g$  and its prefixes are live.  $f$  of  $l_1$  and  $g$  of  $l_2$  are used by the sets of statements  $\{5\}$  and  $\{6\}$ , respectively. The proposed abstraction is shown in the row corresponding to in<sub>5</sub>. At in<sub>2</sub>, access path  $x.h.f$  and its prefixes are live.  $h$  of  $l_4$  and  $f$  of  $l_5$  will be used by the sets of statements  $\{2\}$  and  $\{3,5\}$ . The proposed abstraction is shown in the row corresponding to in<sub>2</sub>. At the join of the control flow paths, the nodes  $f_{\{5\}}$  and  $f_{\{3,5\}}$  are not merged because they are labeled with different sets of use-sites. The spurious access path  $x.h.f.g$  generated in the existing abstraction is not generated here.  $\square$

## 4 Analyses for Heap Liveness

This section formalizes existing greedy liveness [8] (Section 4.3) and our proposed minimal liveness analyses (Section 4.4). Section 4.1 explains the role of aliasing in computing the live memory. It forms the basis of the key difference between the two analyses.

For simplicity of exposition, we have formulated the data flow values in Equations 1 to 8 as sets of access paths of unbounded lengths. In the implementation, each data flow value is represented as a non-deterministic finite automaton in the existing technique (Section 3.1) and as a deterministic finite automaton in the proposed technique (Section 3.2).

### 4.1 The Role of Aliasing

A memory link can be *reached* by more than one access path i.e., a link may correspond to the last field of more than one access paths. Two access paths are said to be *link-aliased* [8] if they share a memory link. For a sound liveness analysis, all access paths that reach a live memory link are recorded. Thus, link-aliases of live access paths are included in the liveness information at each program point so that the full set of live access paths is recorded.

### 4.2 Local Analysis for Computing gen and kill Sets

The local effects of generation and killing of live access paths is represented by  $kill_s$  and  $gen_s$ . As defined in Figure 5, they are parameterized by a set of live access paths denoted  $Liv$ . The figure lists the basic pointer statements in C, excluding those using addressof operator  $\&$  and non-pointer fields, which are handled in Section 4.5.  $kill_s$  is the set of access paths that are killed because its prefix is defined by the statement.

$\text{gen}_s \cdot$  is the set of access paths that are generated because either they are used as “use  $x$ ”, or they are used in the RHS to define a live memory link in the LHS.  $\text{MayLnAin}_s$ ,  $\text{MayLnAout}_s$  and  $\text{MustLnAin}_s$ ,  $\text{MustLnAout}_s$  represent pre-computed may- and must-link-alias<sup>2</sup> information at  $\text{in}_s$  and  $\text{out}_s$ .

### 4.3 Existing Greedy Liveness Analysis

The data flow equations for the existing analysis compute sets of live access paths in  $\widehat{\mathbf{L}}$  or more specifically in  $\widehat{\text{Lin}}_s$  and  $\widehat{\text{Lout}}_s$  at  $\text{in}_s$  and  $\text{out}_s$ .

Intermediate values  $\widehat{\mathbf{L}}' \text{in}_s$  and  $\widehat{\mathbf{L}}' \text{out}_s$  are computed using  $\text{gen}_s \cdot$  and  $\text{kill}_s \cdot$  in Equations 1 and 3. The final  $\widehat{\text{Lin}}_s$  and  $\widehat{\text{Lout}}_s$  are computed in Equations 2 and 4 by including link-aliases of the respective intermediate values. Observe that the link-aliases of access paths are included during the liveness analysis i.e., greedily the full set of live access paths is propagated from  $\text{in}_k$  to  $\text{out}_s$  for all  $k \in \text{succs}$  in Equation 3. Below  $\text{end}$  denotes the ending statement of the program, and  $\text{succs}$  returns the set of control flow successors of statement  $s$  in the control flow graph.

$$\widehat{\mathbf{L}}' \text{in}_s = \widehat{\text{Lout}}_s - \text{kill}_s \widehat{\mathbf{L}} \cup \text{gen}_s \widehat{\mathbf{L}} \quad (1)$$

$$\widehat{\text{Lin}}_s = \bigcup_{\rho \in \widehat{\mathbf{L}}' \text{in}_s} \text{MayLnAin}_s \rho \quad (2)$$

$$\widehat{\mathbf{L}}' \text{out}_s = \begin{cases} \emptyset & s = \text{end} \\ \bigcup_{k \in \text{succs}} \widehat{\text{Lin}}_k & \text{otherwise} \end{cases} \quad (3)$$

$$\widehat{\text{Lout}}_s = \bigcup_{\rho \in \widehat{\mathbf{L}}' \text{out}_s} \text{MayLnAout}_s \rho \quad (4)$$

The example below illustrates intermediate and final sets of live access paths.

**Example 8.** For the program in Figure 3, the intermediate live value  $\widehat{\mathbf{L}}' \text{in}_6$  is  $y.f.g$  and its prefixes. Link aliases are included to obtain the final value  $\widehat{\text{Lin}}_6$  which contains  $x.f.g, x.f, w.f.g, w.f, z.g$  also. This is obtained using  $\text{MayLnAin}_6$  which contains that  $y.f.g$  is link-aliased to  $x.f.g, x.f, z.g$ , and  $x.f.g$  is link-aliased to  $w.f.g, w.f$ . These are propagated backwards to  $\text{out}_3$  and  $\text{out}_4$ .  $\widehat{\text{Lout}}_4$  is imprecise as links of  $l_7 - l_{11}$  are dead.  $\square$

The backward propagation of live link-aliased access paths in the existing technique is the source of imprecision which is handled in the proposed technique in Section 4.4.

Stmt $s$	$\text{kill}_s \text{Liv}$	$\text{gen}_s \text{Liv}$
use $x$	$\emptyset$	$\{x\}$
$x = \text{new}$	$\{x.*\}$	$\emptyset$
$x = \text{null}$	$\{x.*\}$	$\emptyset$
$x = y$	$\{x.*\}$	$\{y.\sigma \mid x.\sigma \in \text{Livout}_s\}$
$x = y \rightarrow f$	$\{x.*\}$	$\{y.f.\sigma \mid x.\sigma \in \text{Livout}_s\}$ $\cup \{y \mid x.\sigma \in \text{Livout}_s\}$
$x \rightarrow f = y$	$\{z.f.* \mid z.f$ $\in \text{MustLnAin}_s x.f\}$	$\{y.\sigma \mid \rho.\sigma \in \text{Livout}_s,$ $\rho \in \text{MayLnAin}_s x.f\} \cup \{x\}$

**Figure 5.** Gen and Kill to compute liveness information at entry and exit of statement  $s$ . Here  $\rho \in \mathbf{V} \times \mathbf{F}^*$  and  $\sigma \in \mathbf{F}^*$ .

### Representing Live Access Paths and their Link Aliases

Each data flow value  $\widehat{\text{Lin}}_s$  and  $\widehat{\text{Lout}}_s$  is represented as a non-deterministic graph by labeling each field with its use-sites. However, some access paths that do not have an explicit use in the program are still discovered by the analysis due to link-alias computation. Hence some fields of link-aliases may not have a use-site. For example,  $x.f$  may be live at a program point due to the use of field  $f$  in a subsequent statement, and  $y.g.f$  may be link-aliased to  $x.f$ . Field  $g$  may not have a use-site because there may be no subsequent statement that uses  $g$  in some access path link aliased to  $y.g$ . We handle this problem by labelling such field nodes with allocation-sites of locations pointed to by the fields. Then field nodes are merged if and only if either their allocation- or use-site is same.

### 4.4 Proposed Minimal Liveness Analysis

To prevent the backward propagation of live link-aliased access paths, we perform a two-phase analysis called *minimal liveness analysis*. Phase 1 uses link-alias information only when required i.e., minimally to generate live access paths used in the RHS of an assignment that define a live link in the LHS. This phase performs fixpoint computation by propagating the access paths backwards in the control flow path. Phase 2 includes link-aliases of live access paths computed in phase 1 to generate the full set of live access paths without backward propagation.

Our proposed data flow equations compute sets of live access paths in  $\mathbf{L}$  or more specifically in  $\text{Lin}_s$  and  $\text{Lout}_s$  at  $\text{in}_s$  and  $\text{out}_s$ , respectively. These are computed in two phases. Intermediate values  $\mathbf{L}' \text{in}_s$  and  $\mathbf{L}' \text{out}_s$  are obtained using a fixpoint computation in Phase 1, and final values are computed in Phase 2.

**Phase 1.** Intermediate values  $\mathbf{L}' \text{in}_s$  and  $\mathbf{L}' \text{out}_s$  are computed using  $\text{gen}_s \cdot$  and  $\text{kill}_s \cdot$ . This phase does not include link-aliases of live access paths. It uses link-aliases to compute  $\text{gen}_s \cdot$  and  $\text{kill}_s \cdot$  (Figure 5).

<sup>2</sup>Must points-to/alias information can be computed from may points-to/alias information [11] or independently [17].

Stmnt $s$	kill <sub>s</sub> Liv	gen <sub>s</sub> Liv
$x = \&y$	$\{x.*\}$	$\{y.\&\sigma \mid x.\sigma \in \text{Livout}_s\}$
$x = \&y \rightarrow f$	$\{x.*\}$	$\{y.f.\&\sigma \mid x.\sigma \in \text{Livout}_s\}$ $\cup \{y \mid x.\sigma \in \text{Livout}_s\}$
$x \rightarrow f = \&y$	$\{z.f.* \mid z.f \in \text{MustLnAin}_s x.f\}$	$\{y.\&\sigma \mid \rho.\sigma \in \text{Livout}_s, \rho \in \text{MayLnAin}_s x.f\} \cup \{x\}$

**Figure 6.** Gen and Kill to compute liveness information at entry and exit of statement  $s$ . Here  $\rho \in \mathbf{V} \times \mathbf{F}^*$  and  $\sigma \in \mathbf{F}^*$ .

$$L'in_s = L'out_s - \text{kill}_s L' \cup \text{gen}_s L' \quad (5)$$

$$L'out_s = \begin{cases} \emptyset & s = \text{end} \\ k \in \text{succ}_s & L'in_k \text{ otherwise} \end{cases} \quad (6)$$

**Phase 2.** The final  $\text{Lin}_s$  and  $\text{Lout}_s$  are computed by including link-aliases of the respective intermediate values computed in Phase 1. This full set of live access paths is not propagated across program points.

$$\text{Lin}_s = \bigcup_{\rho \in L'in_s} \text{MayLnAin}_s \rho \quad (7)$$

$$\text{Lout}_s = \bigcup_{\rho \in L'out_s} \text{MayLnAout}_s \rho \quad (8)$$

The example below illustrates intermediate and final sets of live access paths.

**Example 9.** For the program in Figure 3, in phase 1, the intermediate live value  $L'in_6$  is  $y.f.g$  and its prefixes. This is propagated backwards to  $L'out_3$  and  $L'out_4$  without including link-aliases in phase 1.  $\text{gen}_\cdot$  of statement 3 is  $z$  and  $z.g$  since  $\text{MayLnAin}_6$  contains that  $y.f.g$  is link-aliased to  $x.f.g$ .

In phase 2, link-aliases are included at  $\text{in}_6$  to obtain the final value  $\text{Lin}_6$  which contains  $x.f.g, x.f, z.g$  also. Similarly at  $\text{out}_3$ . At  $\text{out}_4$ , since  $y.f.g$  and its prefixes are not link-aliased to any other access path,  $\text{Lout}_4$  does not generate any spurious access path.  $\square$

### Representing Live Access Paths and their Link Aliases

Each data flow value  $\text{Lin}_s$  and  $\text{Lout}_s$  is represented as a deterministic graph by labeling each field with its set of use-sites. Set of allocation-sites are labeled on link-aliased fields that do not have a use-site (Section 4.3).

#### 4.5 Addressof Operator and Non-Pointer Fields

Until now, we have assumed that all variables and fields are of pointer types. For example, live access path  $x.f$  represents that pointer field  $f$  is dereferenced from the location pointed to by pointer variable  $x$ . We now extend access paths to represent non-pointers also. A non-pointer variable  $x$  and a non-pointer field  $f$  are represented by  $x.\&$  and  $f.\&$ , in the live access paths.

This correctly models C style address expressions ' $\&x$ ' and ' $\&x.f$ ' as pointers. For example, live access path  $x.\&.f$  represents that pointer field  $f$  is dereferenced from a non-pointer variable  $x$ . Live access path  $x.f.\&.g$  represents that non-pointer field  $f$  of the location pointed to by variable  $x$  dereferences pointer field  $g$ .

Liveness analysis of C pointer statements containing  $*$ ,  $\&$ ,  $x \rightarrow f$ , and  $x.f$  is explained below.

- We model  $*$  as field deref; the statement  $x = *y$  is modeled as  $x = y \rightarrow \text{deref}$ . Therefore, before the statements,  $x = *y$ ; use  $x$ , access path  $y.\text{deref}$  is marked as live.
- C pointer statements containing the addressof operator ' $\&$ ' are handled in Figure 6.
- C pointer statements containing  $x \rightarrow f$  (i.e. pointer variable  $x$ ) in LHS/RHS are handled in Figure 5.
- C pointer statements containing  $x.f$  (i.e. non-pointer variable  $x$ ) in LHS/RHS are modeled with  $t \rightarrow f$  where  $t = \&x$ . For example, statement  $x.f = y$ ; is modeled as  $t = \&x; t \rightarrow f = y$ ; Expression  $x.f.g$  in a C statement can also be modeled similarly using only  $\&$  and  $\rightarrow$ .

Thus, Figures 5 and 6 handle all C pointer statements.

## 5 Interprocedural Analysis

We perform context-sensitive interprocedural analysis using value-contexts [10, 14]. We traverse the call graph top-down and represent each context of a call by an input-output pair of data flow values. Thus a new context is created for a procedure only when a new data flow reaches it through some call. The number of contexts is finite because the number of data flow values is finite. This follows from the fact that the total number of field nodes that could be created is bounded by the number of combinations that can be created from the variables, field names, and the use-sites in a program and there are no parallel edges. This enables performing a fully context-sensitive analysis even for recursive calls.

For scalability, we perform access-based localization [13] to eliminate irrelevant data. We observe that not all live access paths of the caller need to be passed to the callees. Live access paths that are not used in the (direct/indirect) callees, can be bypassed from the callees (Section 5.1). Live access paths that are not used in the direct callees but used in the indirect callees, can be memoized in the direct callees (Section 5.2).

### 5.1 Bypassing Unused Information

If a memory link in a caller's live access path is defined in any of its (direct/indirect) callees, then the live access

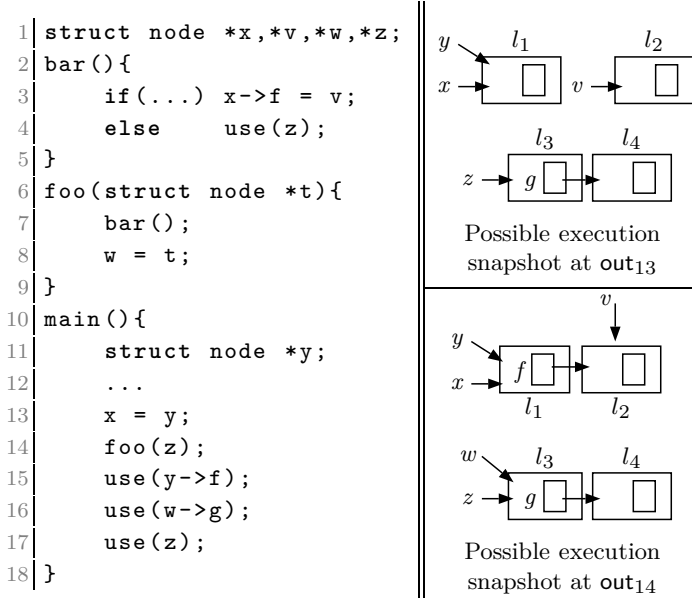

**Figure 7.** Example to illustrate bypassing and memoization used for an efficient interprocedural liveness analysis.

path needs to be passed from the caller to the callees. The rest can be bypassed from the callees.

**Example 10.** There are two function calls, `foo()` and `bar()`, in Figure 7. Live access path `z` of `main()` is not defined in callees, `foo()` and `bar()`. So, we bypass `z` from `foo()` and `bar()`. Live access path `w.g` of `main()` is killed in `foo()` when `w` is defined. So we pass `w.g` from `main()` to `foo()`. Live access path `y.f` of `main()` is defined by `x->f` in `bar()` since `x.f` and `y.f` are link-aliased. So, we pass `y.f` from `main()` to `foo()` and also from `foo()` to `bar()`. Access path `t.g` that is generated in `foo()`, is not defined in `bar()`; therefore, we bypass `t.g` from `bar()`.  $\square$

## 5.2 Memoizing Unaffected Information

If a memory link of a live access path of a caller is defined in an indirect callee and not in the direct callee, then the access path passed to the direct callee will remain unaffected at all program points of the direct callee. Such access paths need not be passed flow-sensitively, and can be memoized in the context of the direct callee flow-insensitively.

**Example 11.** There are two function calls, `foo()` and `bar()`, in Figure 7. Live access path `w.g` of `main()` is killed in `foo()` when `w` is defined i.e., `w.g` is live at `out8` but dead at `in8` and `in7`; thus, `w.g` is passed flow-sensitively in `foo()` context. Live access path `y.f` of `main()` is passed to `foo()` because `y.f` is defined by `x->f` in `bar()`. However, `y.f` is not defined in `foo()` i.e., `y.f` remains unaffected at all program points in `foo()`—`y.f` is live before and after all statements of `foo()`. Therefore, `y.f` can be memoized and

SPEC	kLoC	Funcs	Blocks	Stmts	Allocs	Vars	PT time(s)
lbm	0.9	17	361	326	1	287	0.002
mcf	1.6	22	560	449	3	205	0.018
libq	2.6	55	1236	193	7	322	0.013
milc	5.7	114	3375	1379	5	574	0.176
bzip2	9.5	56	4297	1330	39	1197	0.047
sjeng	10.5	81	5986	373	10	523	0.272
hmmmer	20.6	219	8880	4879	11	3217	3.521
h264ref	36.0	497	23985	16672	163	8489	105.556

**Figure 8.** Number of lines of code, functions, blocks, pointer assignments, allocs, variables, and allocation-sites based points-to analysis time (seconds) in SPEC CPU 2006.

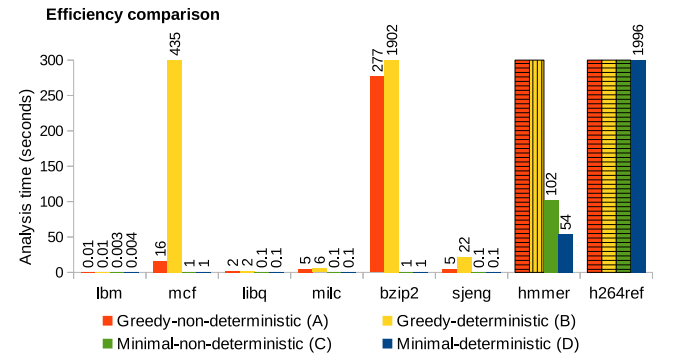

**Figure 9.** Analysis time in seconds of four variants of heap liveness analysis. Bars with horizontal lines denote out-of-memory and bars with vertical lines denote analysis time more than 6 hours.

need not be passed flow-sensitively in `foo()`. However, `y.f` should be passed flow-sensitively in `bar()` because `y.f` is live at `out4`, `in4`, `out3` but dead at `in3`.  $\square$

## 6 Implementation and Measurements

We have implemented flow-, context-, and field-sensitive heap liveness and allocation sites-based points-to analyses [2] in GCC 4.7.2 with LTO on 64bit Ubuntu 14.04 using single Intel core i7-3770 at 3.40 GHz and 8 GiB RAM. We have measured all C heap programs in SPEC CPU2006 up to 36 kLoC. We have manually validated the results on 7 SPEC CPU2006 and 14 SVComp 2016 benchmarks. For validation, we have compared these results with brute force variants that do not perform efficiency related optimizations.

### 6.1 Language Features

All variants of liveness and points-to analyses handle advanced features of C except pointer arithmetic on structures. Targets of function pointers are discovered with points-to analysis. Arrays are abstracted as a single variable without distinguishing between the indices thereby allowing us to ignore pointer arithmetic



## Which Part of the Heap is Useful?

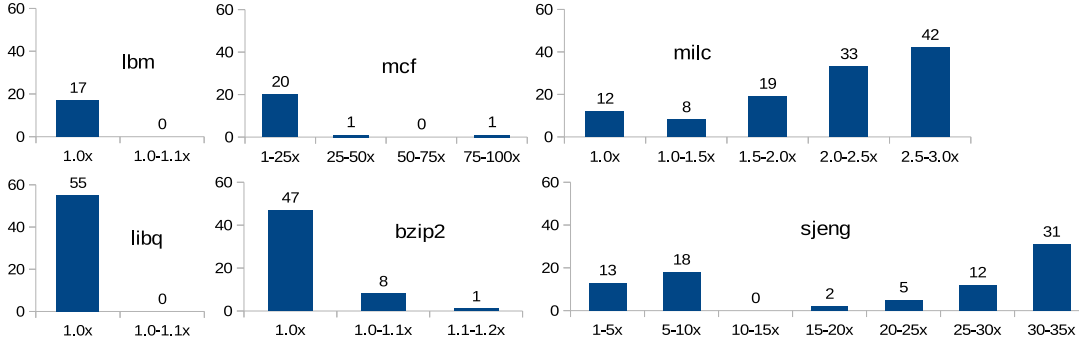

**Figure 10.** Number of times reduction in liveness information computed using proposed technique vs. existing technique in terms of the live access paths in each function. Existing technique does not scale to hmmer and h264ref.

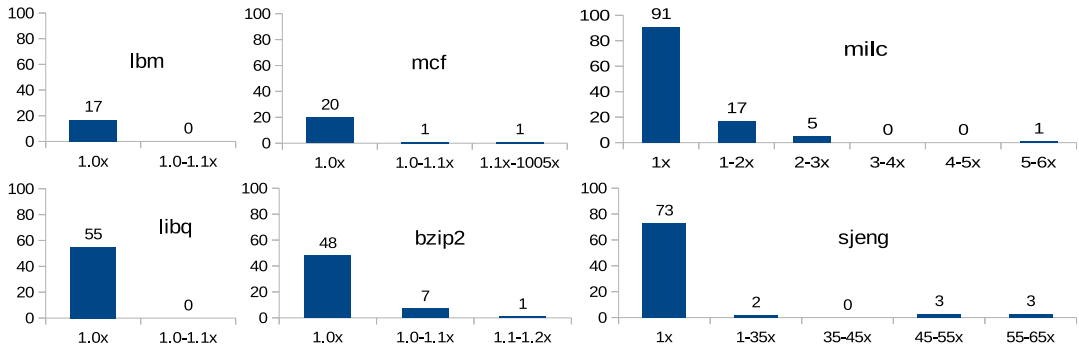

**Figure 11.** Number of times reduction in liveness information computed using proposed technique vs. existing technique in terms of the live access paths within each function's lifetime. Existing technique does not scale to hmmer and h264ref.

on arrays. A function's address escaped variables are not removed because they can be passed to the callers.

### 6.2 Variants of Heap Liveness Analysis

In order to study the impact of greedy vs. minimal liveness analysis and the impact of non-deterministic vs. deterministic automata, we have implemented four combinations of these techniques. The combination viz. greedy liveness with non-deterministic automata (labelled as A in the charts) is the existing technique [8]. The other three combinations (labelled as B, C, and D in the charts) are our proposed improvements. For consistency, we perform efficiency related optimizations (Section 5) on all variants, and we perform strong updates in none of the variants.

### 6.3 Use of Heap Liveness Analysis

It is important to identify the following parts of heap using heap liveness analysis so that one could manage cache misses properly and reclaim unused heap memory.

- Part of the heap that is *live within the lifetime of a function*. This part can be prefetched for efficiency in the cache on call to the function.

**x-axis:** buckets of the number of times reduction in liveness info using proposed vs. existing technique.  
**y-axis:** number of functions.

**For example,** sjeng has 31 functions on which the proposed technique computes 30-35 times smaller liveness info.

**x-axis:** buckets of the number of times reduction in liveness info using proposed vs. existing technique.  
**y-axis:** number of functions.

**For example,** sjeng has 3 functions on which the proposed technique computes 55-65 times smaller liveness info.

- Part of the heap that is *live in a function*. This part is required in the program. The rest can be reclaimed in the function since it remains unused.

**Example 12.** For the program in Figure 7, the following links are live when `foo()` is called:  $x, y, v, z$ , and  $g$  of location  $l_3$ . Out of these the following links are live only within the lifetime of `foo()`:  $x, v$ , and  $z$ . □

### 6.4 Measuring Amount of Heap Liveness Information

We compare variants A, B, C, and D of liveness analysis in terms of the amount of liveness within the lifetime of each function and also in each function. For this, we count the number of live access paths; using allocation-sites to name live objects is too coarse an abstraction. Since different variants summarize access paths differently, a fair comparison is made by reporting access paths of the same length after fixpoint computation. We have chosen to retrieve access paths up to lengths 4 (i.e. a variable followed by 3 fields) for hmmer and up to lengths 5 for rest of the benchmarks. Extraction of longer live access paths from the computed existing liveness graphs, e.g., in hmmer goes out of memory on 8 GB RAM and does not terminate within 24 hours on 165 GB RAM. This length does not

SPEC	Allocated Heap			Live % of Heap in a Function				Live % of Heap in a Function's Lifetime			
				Variant A (conv.)		Variant D (prop.)		Variant A (conv.)		Variant D (prop.)	
	Median	Avg	Max	Median	Min	Median	Min	Median	Min	Median	Min
lbm	3	3	4	100%	100%	100%	100%	50%	33%	50%	33%
mcf	13,058	13,108	23,186	100%	100%	100%	1%	100%	0%	100%	0%
libq	5	4	5	100%	40%	100%	40%	100%	0%	100%	0%
milc	17	16	22	81%	43%	37%	23%	20%	0%	13%	0%
bzip2	2	3,435	102,541	100%	0%	100%	0%	67%	0%	67%	0%
sjeng	128	126	249	98%	0%	4%	0%	1%	0%	1%	0%
hmmmer	225,890	205,029	691,792	?	?	100%	0%	?	?	100%	0%
h264ref	7,890	6,664	11,029	?	?	51%	21%	?	?	5%	0%

E.g., on sjeng, existing analysis reports 98% memory as live; proposed analysis more precisely reports 4% memory as live.

**Figure 12.** Variant D (proposed) more precisely identifies less percentage of heap as live than Variant A (existing). 100% live memory means that there is no scope of memory reclamation, and 0% live memory means that all the received memory can be reclaimed. Variant A does not scale to hmmmer and h264ref. Allocated heap is in terms of number of access paths.

limit the precision of the techniques since the limiting is applied only after fixpoint computation. We extract these counts at the beginning of each function.

### 6.5 Empirical Observations

Below we compare the efficiency, scalability, and amount of liveness information of the four variants of liveness analysis on SPEC CPU2006 benchmarks (Figure 8).

**Scalability and Efficiency.** Figure 9 shows that variants A and B scale to only 10.5 kLoC (sjeng), variant C, due to the use of minimal liveness, scales to 20.6 kLoC (hmmmer), and variant D, due to the use of deterministic automaton, scales to 36 kLoC (h264ref). Comparing A with B and C with D, we see that the use of deterministic automata is more scalable but less efficient than non-deterministic automata since some time is spent in making the graph deterministic. Comparing A with C, we see that minimal liveness is more scalable and significantly more efficient than greedy liveness since it includes link-aliases minimally. Variant D is able to analyse h264ref in 1996 seconds and mcf in 1 second. The average number of edges is 17121 in the existing liveness graph (variant A) and only 5858 in the proposed liveness graph (variant D) of mcf. Overall, variant D (proposed) is more scalable and more efficient than variant A (existing).

**Amount of Liveness Information.** Figures 10 and 11 present the number of times reduction in liveness information computed by variant D versus variant A without compromising on soundness (Appendix B). Amount of liveness information computed by variants B and C is similar to variants A and D, respectively.

As an example, we explain the reduction in liveness information for 81 functions in sjeng (Figure 10). The x-axis of this bar chart has seven buckets: 1-5x, 5-10x, 10-15x, ..., 30-35x. On 31 functions, the proposed

technique computes 30-35 times smaller liveness information. E.g., a function in sjeng receives an allocated heap of 128 access paths; existing technique reports 125 live access paths and proposed technique reports only 4 live access paths. Thus,  $125/4=31.25$  (i.e., 30-35x bucket). Observe that the number of functions shown on all the bars in this chart, add up to 81. Overall, on benchmarks (mcf, milc, sjeng), our technique shows multifold reduction in the amount of computed liveness, ranging from 2 to 100 times (in terms of the number of live access paths), without compromising on soundness. Figure 11 shows that the proposed technique computes 55-65 times smaller liveness in the lifetime of 3 functions in sjeng. In all the charts, the amount of liveness computed using the proposed technique is smaller.

We compute both the allocated memory and the percentage of live access paths to identify benchmarks where memory needs to be reclaimed and cache misses need to be managed (Figure 12). The median of the live percentage of access paths for 81 functions in sjeng is 4% using the proposed technique. This median in bzip2 and hmmmer is poor (100% access paths is live). However, the minimum on bzip2 and hmmmer is good (0% access paths is live) and the standard deviation (not shown in the table) is 17% and 48% respectively. Median 37% indicates that half the number of functions have a liveness smaller than 37%. Median 100% indicates that a majority of the functions have a liveness of 100%. Overall, we see that in SPEC CPU2006, very small percentages of the allocated heap are used both in a function and within its lifetime.

Note that the count of live access paths does not say anything conclusively about the relative precision of our proposed technique. This is because the numbers include aliased access paths too and a coarse aliasing may inflate the number without actually

over-approximating the set of live locations. Precision is studied in Appendix C.

## 7 Related Work

We have already presented a detailed comparison with the existing technique [8], which comes closest to our work. This section highlights other work related to backward analyses. Details on forward heap analyses can be found elsewhere [7].

Heap liveness information has been modeled as a store-based [1, 9, 11, 15] and storeless [3–5, 8]. The former uses allocation-sites, types, variables that point to the same locations, and the latter uses access paths.

Shape analysis techniques [1, 15] first build a heap points-to graph based on three-valued logic in a forward analysis. Live objects are then marked on the points-to graph in a backward analysis using heap safety automaton [15] and reference counting [3]. These techniques scale to small benchmarks of SPECjvm98 [15] and handwritten programs [1].

Allocation-sites [9, 11] based summarization of heap liveness is coarse since even large benchmarks contain few allocation-sites (Figure 8). For each allocation-site, the program is sliced using def-use chains with its value-flow dependences computed using Anderson’s points-to analysis to check memory leaks [19, 20, 24].

The number of distinctions made by context sensitive heap cloning [12, 18, 22, 23] is a much bigger exponential than that made by sets of access paths. However, the distinctions need not be made for all interprocedural paths but only for the paths that use a heap location differently. If an allocation site has a million call contexts reaching it but the location is always referred to by the access path  $x.f$ , there is no precision gain by distinguishing between all these million heap clones as they are used in the same way in the program. Thus, literature [18, 23] merges contexts with equivalent points-to information. However, they scale at the cost of precision (they are flow-insensitive, 1-object-sensitive, perform  $k$ -limiting equivalence of points-to graphs) and are demand based.

Liveness analysis of only stack variables [4, 5] has also been performed by considering all heap objects as live.

Techniques that use access paths [16] are incomparable to our work since they compute points-to information (and not liveness information like us), and perform demand driven analysis (and not exhaustive analysis like us). Techniques make points-to graph deterministic [21] to only check equivalence of graphs using HK algorithm; unlike us they do not store it in a deterministic graph.

## 8 Conclusions

Heap liveness analysis can be used to reclaim unused heap memory and improve cache behaviour. Existing heap liveness analysis [8] performs greedy analysis, which includes aliases of live access paths during backward liveness analysis for soundness. We show how aliases can be considered minimally in a sound analysis. This reduces the amount of liveness information, and improves efficiency and scalability.

Further, the existing technique assumes that repeating  $f_s$  in an access path (where  $f$  is a field and  $s$  is its use-site) indicates that sequences of fields after repeating  $f_s$  would be same. We observe that this need not always be the case and it is possible that the sequences of fields after repeating  $f_s$  may be different in access paths if all use-sites of the repeating  $f$  are not the same along all execution instances. We show that it is more precise to assume that the sequences of fields are same if repeating  $f$  are dereferenced in the same set of statements along all execution instances. This improves scalability.

Our empirical measurements on SPEC CPU2006 benchmarks show that improved liveness analysis scales to 36 kLoC (existing analysis scales to 10.5 kLoC) and improves efficiency even up to 99%. For some of the benchmarks (mcf, milc, sjeng, hmmr, h264ref) our technique shows multifold reduction in the amount of liveness information, ranging from 2 to 100 times (in terms of the number of live access paths), without compromising on soundness.

## References

- [1] G. Arnold, R. Manevich, M. Sagiv, and R. Shaham. 2006. Combining Shape Analyses by Intersecting Abstractions. In *Proceedings of the 7th International Conference on VMCAI 2006*. Springer-Verlag, Berlin, Heidelberg, 33–48.
- [2] D.R. Chase, M. Wegman, and F.K. Zadeck. 1990. Analysis of Pointers and Structures. In *Proceedings of the ACM SIGPLAN Conference on PLDI 1990*. ACM, NY, 296–310.
- [3] Sigmund Chereh and Radu Rugina. 2006. Compile-time Deallocation of Individual Objects. In *Proceedings of the 5th ISMM 2006*. ACM, New York, NY, USA, 138–149.
- [4] S.Z. Guyer, K.S. McKinley, and D. Frampton. 2006. FreeMe: A Static Analysis for Automatic Individual Object Reclamation. In *Proceedings of ACM SIGPLAN Conference on PLDI 2006*. ACM, NY, 364–375.
- [5] Martin Hirzel, Amer Diwan, and Johannes Henkel. 2002. On the Usefulness of Type and Liveness Accuracy for Garbage Collection and Leak Detection. *ACM Trans. Program. Lang. Syst.* 24, 6 (Nov. 2002), 593–624.
- [6] Vini Kanvar and Uday Khedker. 2017. What’s in a name? Going beyond allocation site names in heap analysis. *Proceedings of the 2017 ACM SIGPLAN International Symposium on Memory Management (2017)*, 92–103.
- [7] Vini Kanvar and Uday P. Khedker. 2016. Heap Abstractions for Static Analysis. *ACM Comput. Surv.* 49, 2, Article 29 (June 2016), 47 pages.

- [8] Uday Khedker, Amitabha Sanyal, and Amey Karkare. 2007. Heap Reference Analysis Using Access Graphs. *ACM Trans. Program. Lang. Syst.* 30, 1, Article 1 (Nov. 2007), 41 pages.
- [9] Uday P. Khedker and Vini Kanvar. 2014. Generalizing the Liveness Based Points-to Analysis. *CoRR* abs/1411.5289 (2014).
- [10] Uday P. Khedker and Bageshri Karkare. 2008. Efficiency, Precision, Simplicity, and Generality in Interprocedural Data Flow Analysis: Resurrecting the Classical Call Strings Method. In *Proc. of the Joint ETAPS'08 and 17th Int'l Conf. on CC'08*. Springer-Verlag, Berlin, Heidelberg, 213–228.
- [11] Uday P. Khedker, Alan Mycroft, and Prashant Singh Rawat. 2012. Liveness-Based Pointer Analysis. In *Proceedings of the 19th International Conference on Static Analysis (SAS'12)*. Springer-Verlag, Deauville, France, 265–282.
- [12] Chris Lattner, Andrew Lenharth, and Vikram Adve. 2007. Making Context-sensitive Points-to Analysis with Heap Cloning Practical for the Real World. In *Proceedings of the 2007 ACM SIGPLAN Conference on Programming Language Design and Implementation (PLDI '07)*. ACM, New York, NY, USA, 278–289.
- [13] Hakjoo Oh and Kwangkeun Yi. 2011. Access-Based Localization with Bypassing. In *Proceedings of the 9th APLAS'11*. Springer-Verlag, Berlin, Heidelberg, 50–65.
- [14] Rohan Padhye and Uday P. Khedker. 2013. Interprocedural Data Flow Analysis in Soot Using Value Contexts. In *Proc. of 2nd SIGPLAN Int'l W's on SOAP'13*. ACM, NY, 31–36.
- [15] R. Shaham, E. Yahav, E.K. Kolodner, and M. Sagiv. 2003. Establishing Local Temporal Heap Safety Properties with Applications to Compile-time Memory Management. In *Proc. of 10th Int'l Conf. SAS'03*. Springer-Verlag, Berlin, 483–503.
- [16] Johannes Spaeth, Lisa Nguyen Quang Do, Karim Ali, and Eric Bodden. 2016. Boomerang: Demand-Driven Flow- and Context-Sensitive Pointer Analysis for Java. In *ECOOP*.
- [17] Manu Sridharan, Satish Chandra, Julian Dolby, Stephen J. Fink, and Eran Yahav. 2013. Aliasing in Object-Oriented Programming. In *Alias Analysis for Object-oriented Programs*, Dave Clarke, James Noble, and Tobias Wrigstad (Eds.). Springer-Verlag, Berlin, Heidelberg, 196–232.
- [18] Yulei Sui, Yue Li, and Jingling Xue. 2013. Query-directed Adaptive Heap Cloning for Optimizing Compilers. In *Proceedings of the 2013 IEEE/ACM International Symposium on Code Generation and Optimization (CGO '13)*. IEEE Computer Society, Washington, DC, USA, 1–11.
- [19] Yulei Sui, Ding Ye, and Jingling Xue. 2012. Static Memory Leak Detection Using Full-sparse Value-flow Analysis. In *Proceedings of the 2012 International Symposium on Software Testing and Analysis (ISSTA 2012)*. ACM, New York, NY, USA, 254–264.
- [20] Yulei Sui, Ding Ye, and Jingling Xue. 2014. Detecting Memory Leaks Statically with Full-Sparse Value-Flow Analysis. *IEEE Trans. Softw. Eng.* 40, 2 (Feb. 2014), 107–122.
- [21] Tian Tan, Yue Li, and Jingling Xue. 2017. Efficient and Precise Points-to Analysis: Modeling the Heap by Merging Equivalent Automata. *SIGPLAN Not.* 52, 6 (June 2017), 278–291.
- [22] John Whaley and Monica S. Lam. 2004. Cloning-based Context-sensitive Pointer Alias Analysis Using Binary Decision Diagrams. In *Proceedings of the ACM SIGPLAN 2004 Conference on Programming Language Design and Implementation (PLDI '04)*. ACM, New York, NY, USA, 131–144.
- [23] Guoqing Xu and Atanas Rountev. 2008. Merging Equivalent Contexts for Scalable Heap-cloning-based Context-sensitive Points-to Analysis. In *Proceedings of the 2008 International Symposium on Software Testing and Analysis (ISSTA '08)*. ACM, New York, NY, USA, 225–236.
- [24] Hua Yan, Yulei Sui, Shiping Chen, and Jingling Xue. 2016. Automated Memory Leak Fixing on Value-flow Slices for C Programs. In *Proceedings of the 31st Annual ACM Symposium on Applied Computing (SAC '16)*. ACM, New York, NY, USA, 1386–1393.

## A Abstracting Live Heap: Example

Figure 13 gives a step by step working of the existing and the proposed liveness analyses on the program in Figure 2. The proposed abstraction is not only more precise than the convention abstraction but takes less number of iterations to reach fixpoint.

## B Soundness

In this section, we define liveness for an execution and then use it to prove soundness of our proposed heap liveness analysis.

### B.1 Definition of Liveness for an Execution

Let  $\pi$  denote an execution path represented by a sequence of possibly repeating statements. Let  $\overline{\text{LnA}}_{q,\pi}, \rho$  denote link alias information of access path  $\rho$  in the concrete memory at  $q$  for the execution path  $\pi$ .  $\overline{\text{LnA}}_{in_s,\pi}, \rho$  and  $\overline{\text{LnA}}_{out_s,\pi}, \rho$  denote link alias information at entry and exit of statement  $s$ .

Let  $q_b$  and  $q_a$  denote program points before and after a sequence of one or more statements in an execution path. We relate the access paths at  $q_a$  to the access paths at  $q_b$  by incorporating the effect of both the intervening statements and of the statements executed before  $q_b$ .

Given an access path  $\rho$  at  $q_a$ , we define a transfer function  $\mathbb{T}\pi', \pi, \rho$  representing a set of access paths at  $q_b$  that can be used to reach the link represented by the last field of  $\rho$ . The parameters of  $\mathbb{T}\pi', \pi, \rho$  are explained below.

- $\pi$  is an execution path from start of the program<sup>3</sup>.
- $\pi'$  is a sequence of statements in  $\pi$  that appear between program points  $q_b$  and  $q_a$ .
- $\rho$  is an access path of interest at  $q_a$ .

$\mathbb{T}\pi', \pi, \rho$  is defined using  $\mathbb{R}\pi', \pi, \rho$  as follows.

$$\mathbb{T}\pi', \pi, \rho = \overline{\text{LnA}}_{q_b,\pi}, \mathbb{R}\pi', \pi, \rho$$

Function  $\mathbb{R}$ , defined in Figure 14<sup>4</sup>, captures the transitive effect of backward transfers of  $\rho$  through  $\pi'$ ,

<sup>3</sup>Execution path  $\pi$  is required in the transfer function  $\mathbb{T}$  to find link aliases along this execution path.

<sup>4</sup>The definition has been adapted from existing heap liveness analysis [8]. The existing technique does not use link aliases in its soundness proof although it uses in the data flow equations.

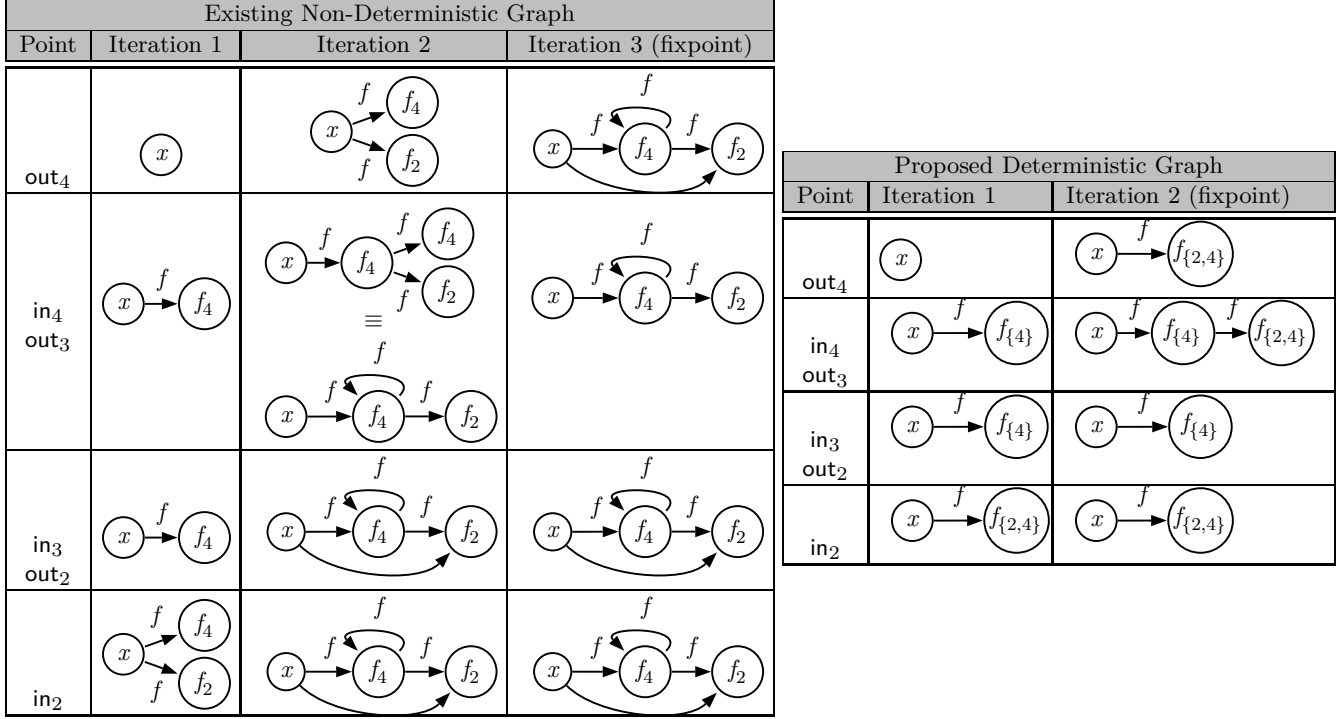

**Figure 13.** Step by step working of existing and proposed liveness analyses on the program in Figure 2. Each node represents live access path(s) reaching it. Each node’s field label is same as its in-edge label. For simplicity, aliases of the access paths are not included, and live access paths rooted at only  $x$  are shown.

and also considers alias information from **start** of the program to end of  $\pi'$  i.e., until  $q_a$ .

## B.2 Proving Soundness

This section proves the soundness of Equations 5, 6, 7, and 8 (this proof has been adapted from existing heap liveness analysis [8]).

**Theorem 1.** Let  $\rho^a$  be computed in some proposed liveness graph at  $q_a$ . Let the sequence of statements between  $q_b$  to  $q_a$  be  $\pi'$  along an execution path  $\pi$ . Then, for  $\top\pi', \pi, \rho^a = \Sigma^b$ , all access paths in  $\Sigma^b$  will be computed in some proposed liveness graph at  $q_b$ .

*Proof.* The proof is by structural induction on  $\pi'$ . The inductive step corresponds to the last case in the definition of  $R\pi', \pi, \rho^a$  and the based cases correspond to the rest of the cases in the definition of  $R\pi', \pi, \rho^a$ . The base cases are:

1.  $\pi'$  is a use statement. In this case,  $\Sigma^b$  is a subset of may-link aliases of  $\rho^a$  i.e.,  $\text{MayLnAin}_{\pi'}\rho^a$ .
2.  $\pi'$  is an assignment  $x = \dots$  such that  $x$  is not a prefix of  $\rho^a$ . Here also  $\Sigma^b$  is a subset of the may-link aliases of  $\rho^a$  i.e.,  $\text{MayLnAin}_{\pi'}\rho^a$ .
3.  $\pi'$  is an assignment  $x \rightarrow f = \dots$  such that  $\rho, \rho \in \text{MustLnAin}_{\pi'}x.f$ , where  $\rho$  is a prefix of  $\rho^a$ . Here also

$\Sigma^b$  is a subset of the may-link aliases of  $\rho^a$  i.e.,  $\text{MayLnAin}_{\pi'}\rho^a$ .

4.  $\pi'$  is an assignment  $x = y$  such that  $\rho^a = x.\sigma$ . In this case,  $\Sigma^b$  is a subset of the may-link aliases of  $y.\sigma$  i.e.,  $\text{MayLnAin}_{\pi'}y.\sigma$ .
5.  $\pi'$  is an assignment  $x = y \rightarrow f$  such that  $\rho^a = x.\sigma$ . In this case,  $\Sigma^b$  is a subset of the may-link aliases of  $y.f.\sigma$  i.e.,  $\text{MayLnAin}_{\pi'}y.f.\sigma$ .
6.  $\pi'$  is an assignment  $x \rightarrow f = y$  such that  $\forall \sigma, \rho^a = \rho.\sigma$ , where  $\rho \in \text{MayLnAin}_{\pi'}x.f$ . In this case,  $\Sigma^b$  is a subset of the may-link aliases of all  $y.\sigma$  i.e.,  $\bigvee_{\sigma} \text{MayLnAin}_{\pi'}y.\sigma$ .

For points 1, 2, and 3 above, since  $\rho^a$  is not in  $\text{kill}_{\pi'}$ , access paths in  $\Sigma^b$  are in some proposed liveness graph at  $q_b$ . For the remaining points, since  $\Sigma^b = \text{Lin}_{\pi'}$  (Equation 7) represented with an equivalent automaton<sup>5</sup>, we see that access paths in  $\Sigma^b$  are in some proposed liveness graph at  $q_b$ .

For the inductive step, assume that the lemma holds for  $\pi_1$  and  $\pi_2$ . From the definition of  $\top$ , there exists a set of access paths  $\Sigma^i$  at the intermediate program point  $q_i$  between  $\pi_1$  and  $\pi_2$ , such that  $\Sigma^i = \top\pi_2, \pi, \rho^a$ .

<sup>5</sup>A set of access paths with unbounded lengths is summarized by merging fields with the same set of use-sites. This creates a finite automaton, which is an over-approximation of the set of computed access paths by the proposed technique at the program point.

$$R\pi', \pi, \rho = \begin{cases} \rho' \in R\pi_2, \pi, \rho & \text{if } \pi' \text{ is a sequence } \pi_1; \pi_2 \\ \{y.\sigma\} & \text{if } \pi' \text{ is } x = y, \quad \rho = x.\sigma \\ \{y.f.\sigma\} & \text{if } \pi' \text{ is } x = y \rightarrow f, \quad \rho = x.\sigma \\ \{y.\sigma\} & \text{if } \pi' \text{ is } x \rightarrow f = y, \quad \forall \sigma, \rho = \rho'.\sigma, \\ & \rho' \in \overline{\text{LnAin}}_{\pi'} \pi, x.f \\ \{\rho\} & \text{if } \pi' \text{ is a use stmt} \\ \{\rho\} & \text{if } \pi' \text{ is } x = \dots, \quad x \text{ is not a prefix of } \rho \\ \{\rho\} & \text{if } \pi' \text{ is } x \rightarrow f = \dots, \quad \rho', \rho' \in \overline{\text{LnAin}}_{\pi'} \pi, x.f \\ & \text{where } \rho' \text{ is a prefix of } \rho \\ \emptyset & \text{if } \pi' \text{ is } x = \text{new}, \quad \rho = x.\sigma \\ \emptyset & \text{if } \pi' \text{ is } x = \text{null}, \quad \rho = x.\sigma \\ \{\rho\} & \text{otherwise} \end{cases}$$

Figure 14. Defining liveness for an execution.

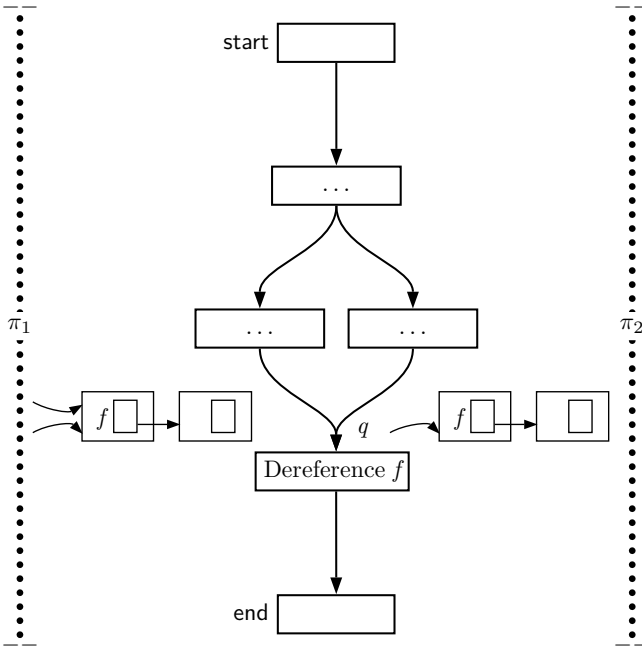

Figure 15. Representative feature #1 in programs.

Now we need to transfer all access paths  $\rho^i \in \Sigma^i$  to program point  $q_b$  i.e.,  $\Sigma^b = \bigcup_{\rho^i \in \Sigma^i} \text{Tr}\pi_1, \pi, \rho^i$ . Since  $\rho^a$  is in some proposed liveness graph at  $q_a$ , by the inductive hypothesis, access paths in  $\Sigma^i$  must be in some proposed liveness graph at  $q_i$ . Further, by the induction hypothesis, access paths in  $\Sigma^b$  must be in some proposed liveness graph at  $q_b$ .  $\square$

## C Program Characteristics for Precision Benefit

```

struct node {
    int data;
    struct node * next;
};

1 main() {
2     struct node *head, *tmp;
3     list_alloc(tmp);
4     switch(option) {
5     case shallow_copy:
6         head = tmp;
7         break;
8     case deep_copy:
9         t=tmp;
10        head=new;
11        h=head;
12        while(t) {
13            h->data=t->data;
14            h->next=new;
15            h=h->next;
16            t=t->next;
17        }
18        break;
19    }
20    for ...
21        head=head->next;
22 }

```

Figure 16. Representative feature # 1. Shallow and deep copy of a linear linked list. Locations reachable by  $tmp.next^*$  are dead at the end of the deep copy and can be garbage collected by proposed liveness analysis but not by existing.

Below are two representative features in SPEC CPU2006 benchmarks and common algorithms that show a precision benefit with the use of proposed heap liveness analysis as compared to the use of existing heap liveness analysis.

- Representative feature #1

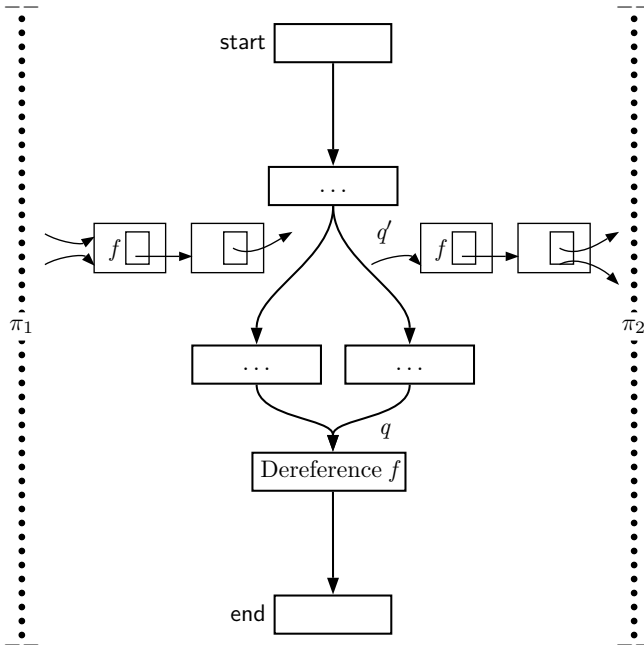

Figure 17. Representative feature #2 in programs.

```

struct user_t {
    int uid;
    struct file_t * fhead;
    struct user_t * unext;
};
struct file_t {
    int fid;
    struct fdata_t * fdata;
    struct file_t * fnext;
};
...

1 main() {
2     ...
3     create_file(uid, fid);
4 }
5 create_file(int uid, int fid){
6     user_t * user = root;
7     file_t * file = user->fhead;
8     if(uid is allowed) {
9         while(user->uid != uid)
10            user = user->unext;
11        file = user->fhead;
12        while(file->fnext->fid != fid)
13            file = file->fnext;
14        file->fnext->fdata = new;
15    }
16    use(file->fnext->fdata);
17 }

```

Figure 18. Representative feature # 2. An operation on two-level directory structure. Locations reachable by *user.unext.fhead.fnext\*.data* are dead at exit of statement 3 and can be garbage collected by proposed liveness analysis but not by existing.

- Two different control flow paths  $\pi_1$  and  $\pi_2$ , both from the start to end of the program via a common program point  $q$ . Field  $f$  is used at program point  $q$ . Prefixes of field  $f$  at  $q$  along control flow path  $\pi_1$  are different from those at  $q$  along  $\pi_2$  (Figure 15).
- Figure 3 is an example of such a program.
- This representative feature can be found in SVComp benchmarks and in SPEC CPU2006 benchmarks. We found at least half a dozen such cases in h264ref; e.g., *terminate\_slice()*, *CheckAvailabilityOfNeighbours()*, *intrapred\_luma\_16x16()*, *slice\_too\_big()*.
- Deep copy and shallow copy of a linked list (Figure 16) is such a common algorithm.
- Representative feature #2
  - Two different control flow paths  $\pi_1$  and  $\pi_2$ , both from the start to end of the program via common program points  $q$  and  $q'$ . Field  $f$  is used at program point  $q$  and is live at program point  $q'$ . The prefixes and suffixes of field  $f$  accessed in the memory graph after  $q'$  along  $\pi_1$  are different from those accessed in the memory graph after  $q'$  along  $\pi_2$  (Figure 17).
  - Figure 4 is an example of such a program.
  - This representative feature is less common and harder to find. Functions in h264ref are *terminate\_slice()* and *terminate\_macroblock()*.
  - Creation of a new file in a two-level directory structure (Figure 18) is such a common algorithm.