

REVISIONS

ENGINEERING THE FUTURE.
13500 REECK ROAD
SOUTHGATE, MI 48195
(734) 759-1600
FAX (734) 282-6566
WWW.HENGINEERS.COM



TITLE PAVING DETAILS
CITY OF ECORSE
WAYNE COUNTY, MICHIGAN

CUL-DE-SAC DETAIL

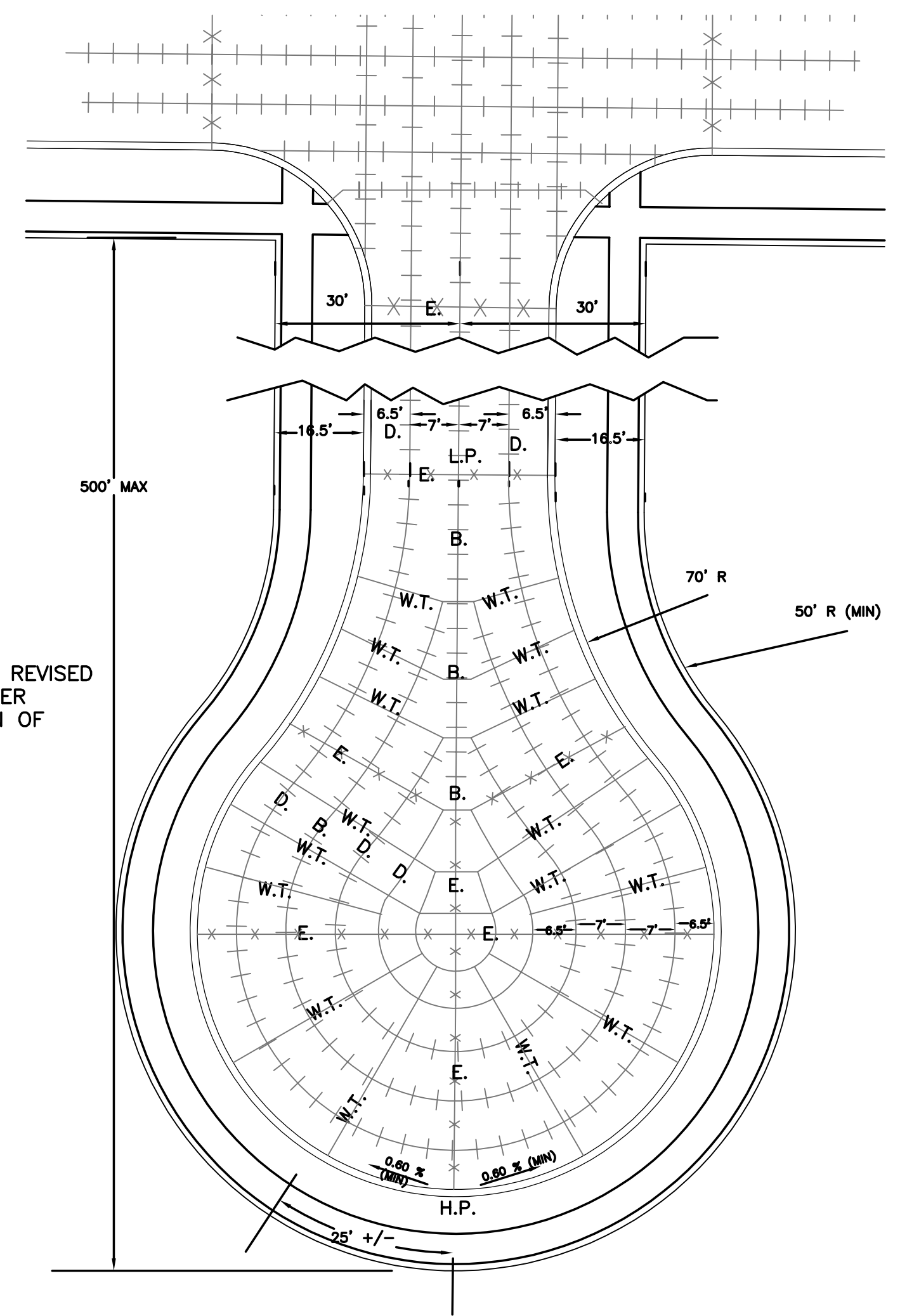

NOTE:
JOINT LOCATION MAY BE REVISED
AS DIRECTED BY ENGINEER
DEPENDENT ON LOCATION OF
DRAINAGE STRUCTURES.

B: LONGITUDINAL BULKHEAD CONSTRUCTION JOINT.
D: LONGITUDINAL LANE TIE JOINT.
E: EXPANSION JOINT.
WT: TRANSVERSE WEAKENED PLANE JOINT

EYEBROW DETAIL

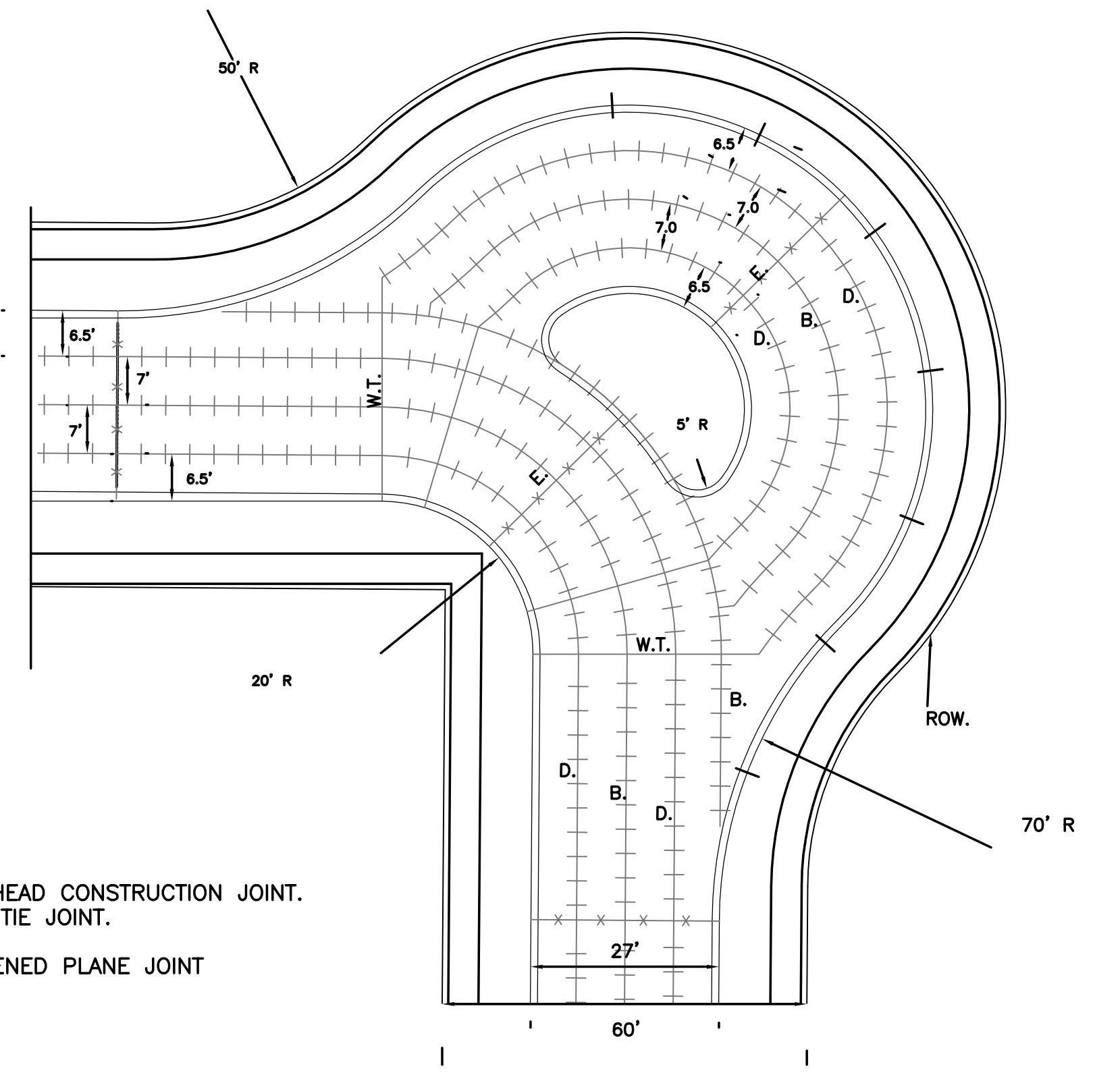

B: LONGITUDINAL BULKHEAD CONSTRUCTION JOINT.
D: LONGITUDINAL LANE TIE JOINT.
E: EXPANSION JOINT.
WT: TRANSVERSE WEAKENED PLANE JOINT

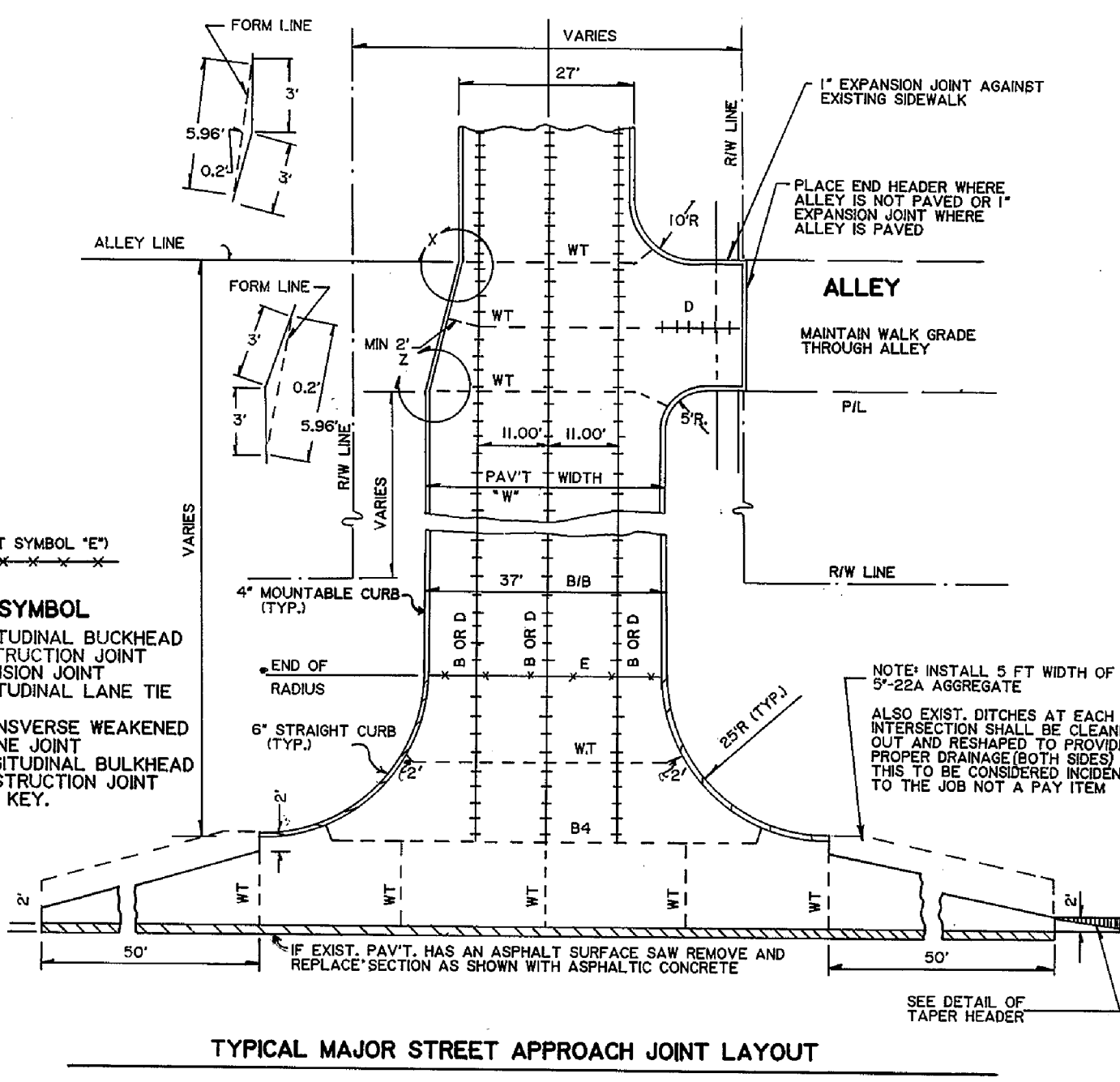

TYPICAL MAJOR STREET APPROACH JOINT LAYOUT

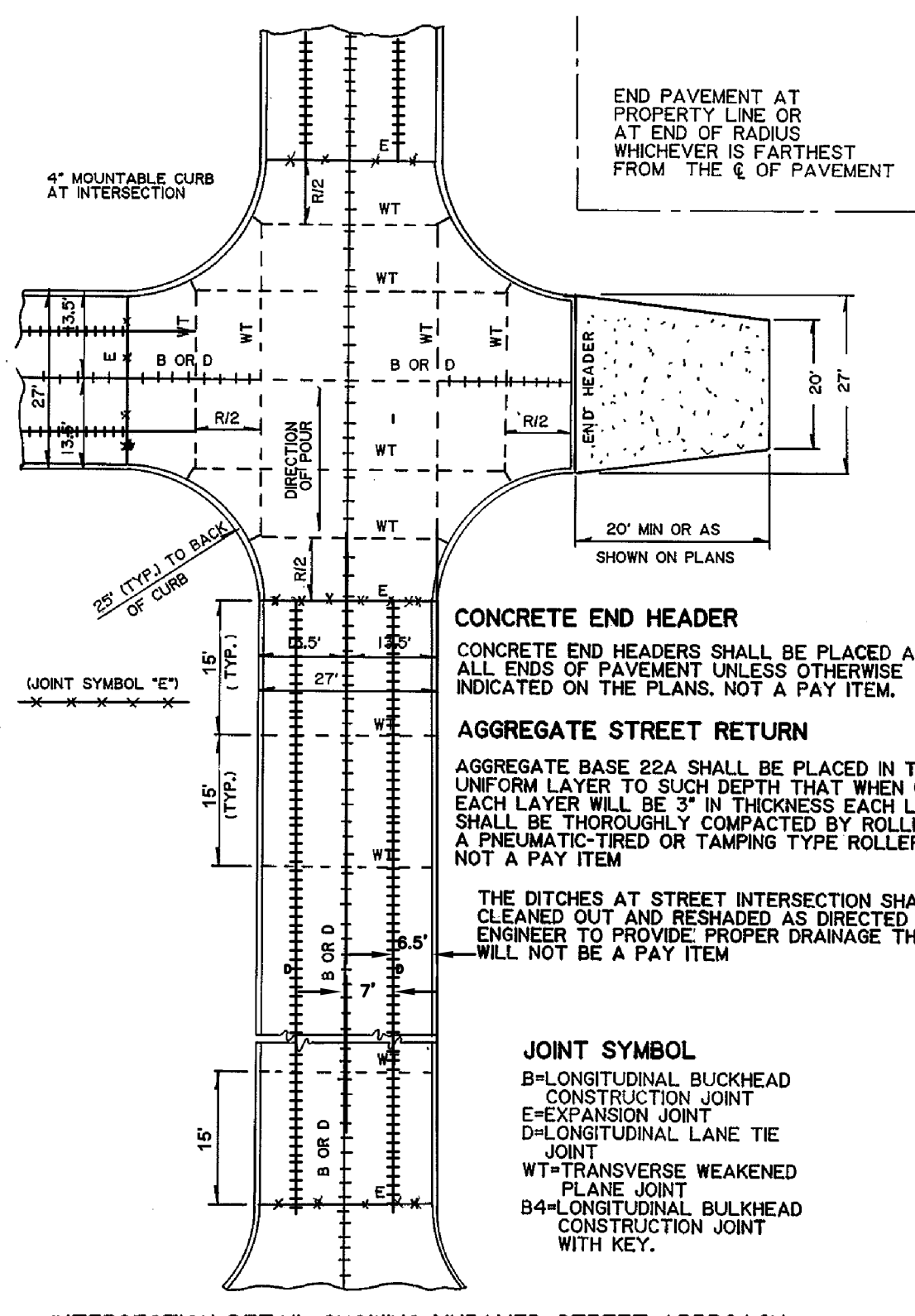

INTERSECTION DETAIL-SHOWING UNPAVED STREET APPROACH

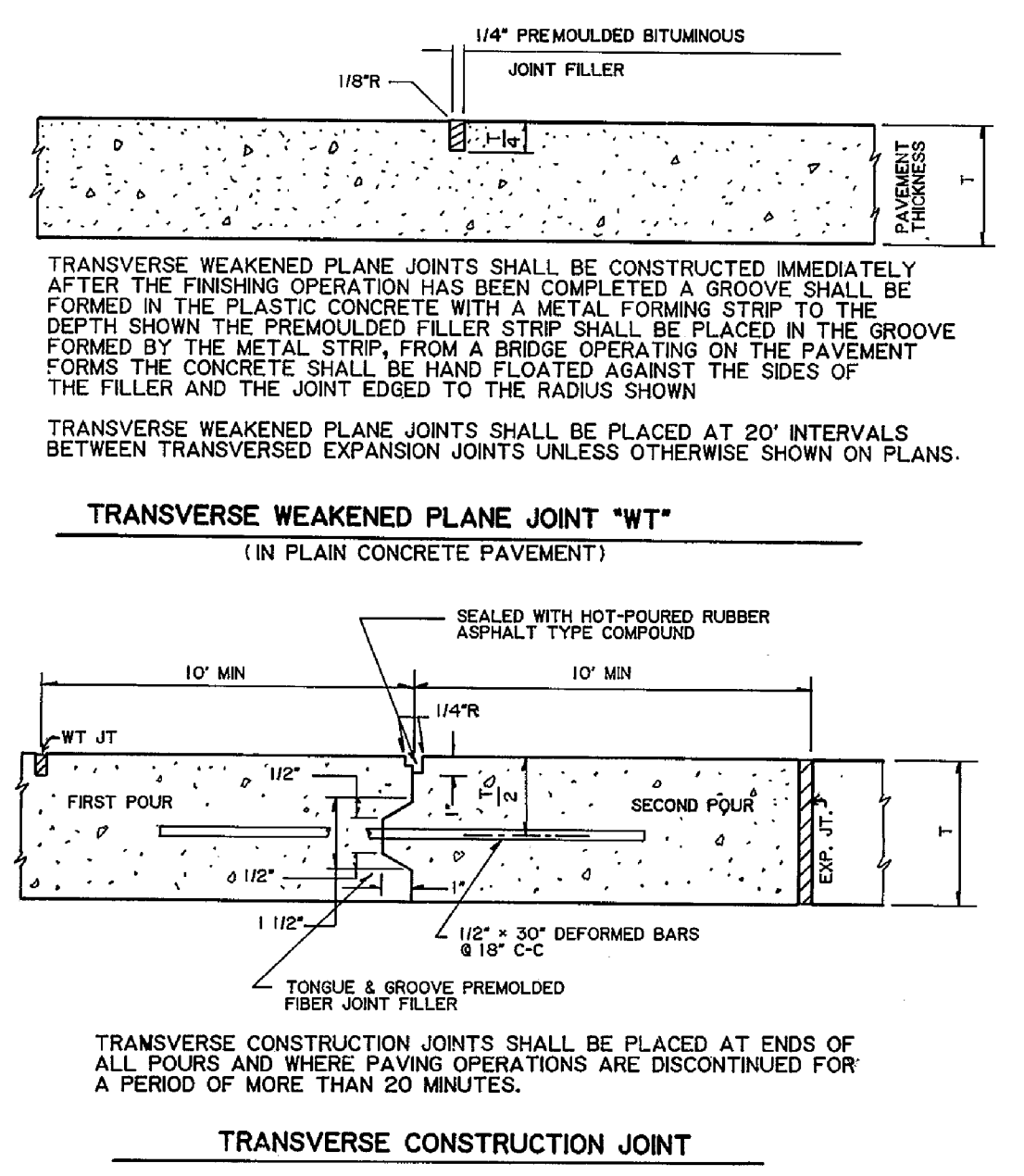

TRANSVERSE WEAKENED PLANE JOINT "WT"
(IN PLAIN CONCRETE PAVEMENT)

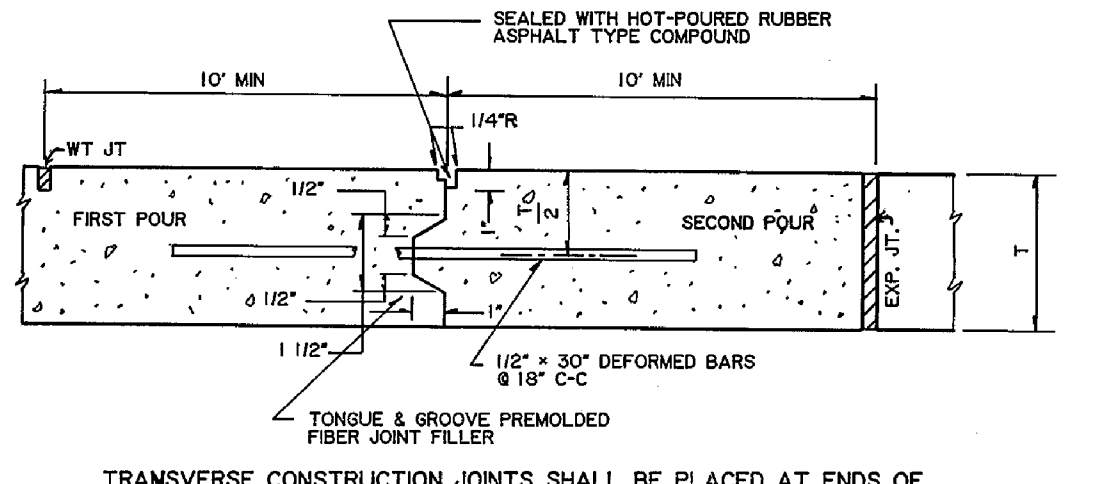

TRANSVERSE CONSTRUCTION JOINT

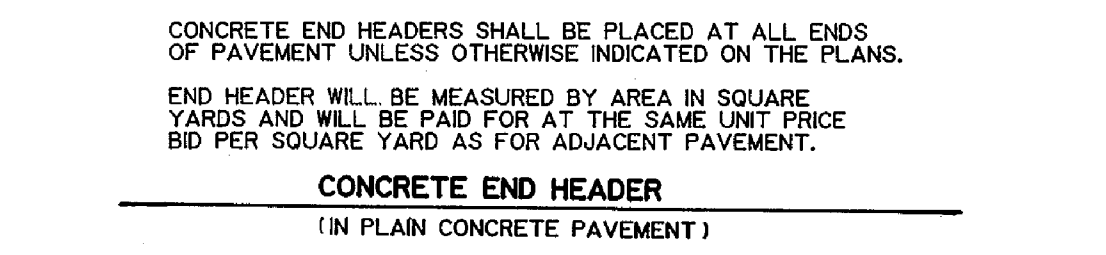

CONCRETE END HEADER
(IN PLAIN CONCRETE PAVEMENT)

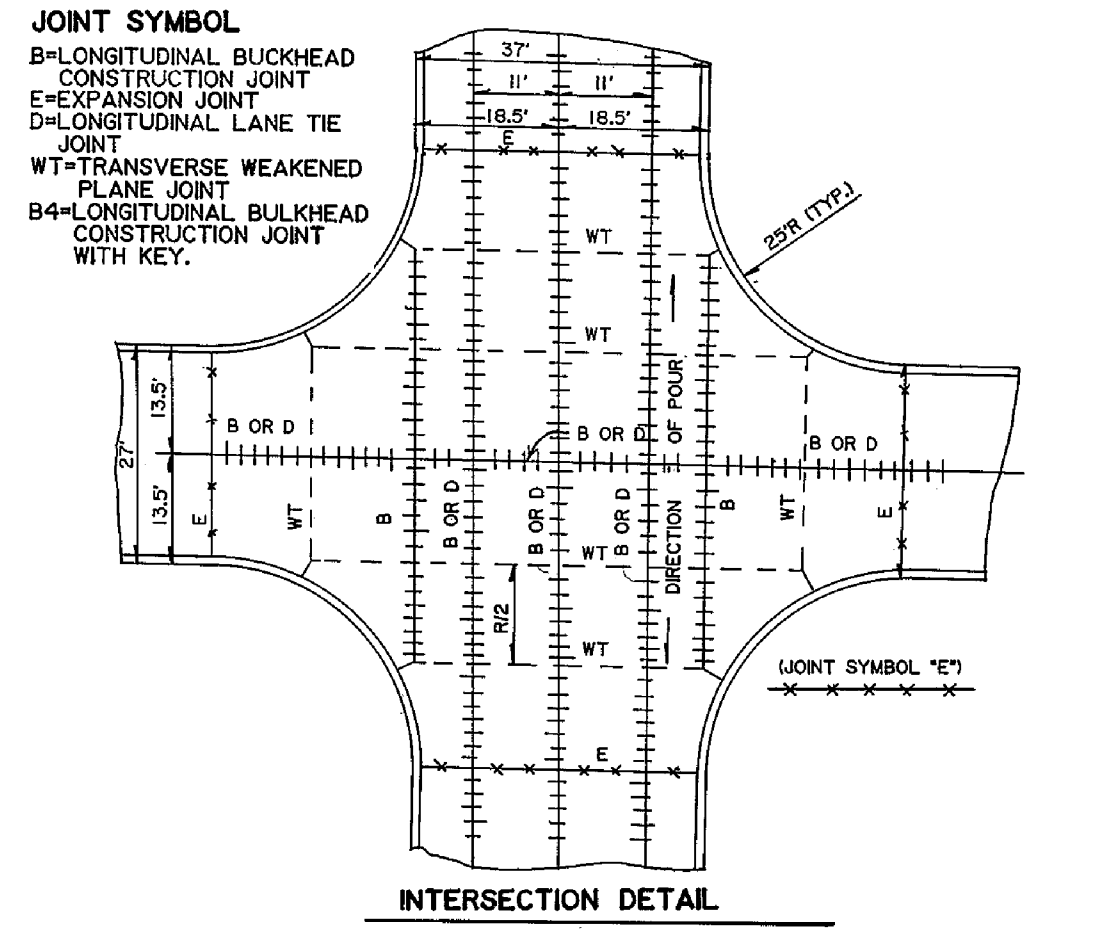

INTERSECTION DETAIL

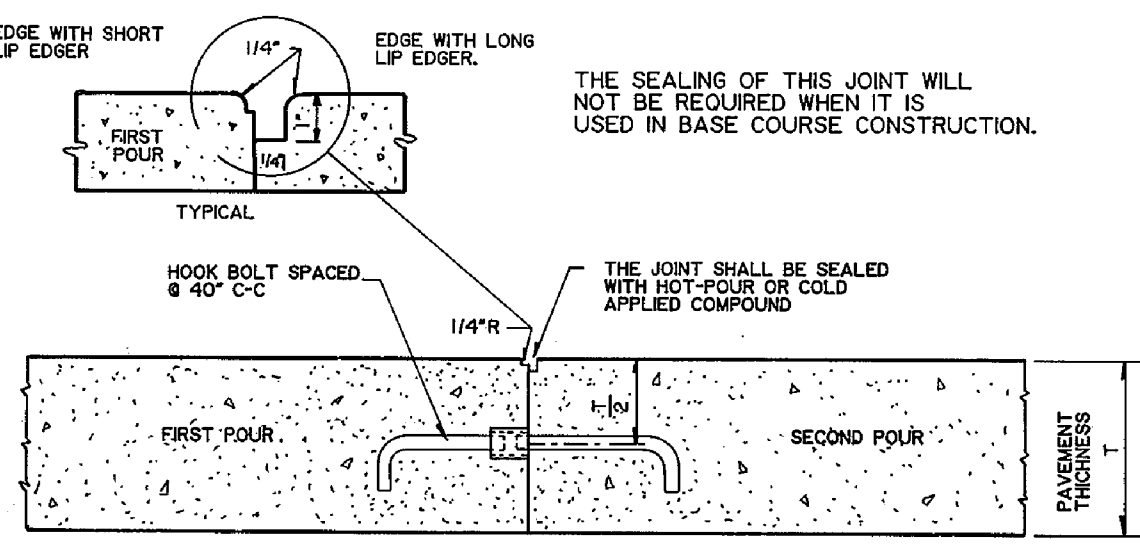

LONGITUDINAL BULKHEAD CONSTRUCTION JOINT "B"
(IN PLAIN CONCRETE PAVEMENT)

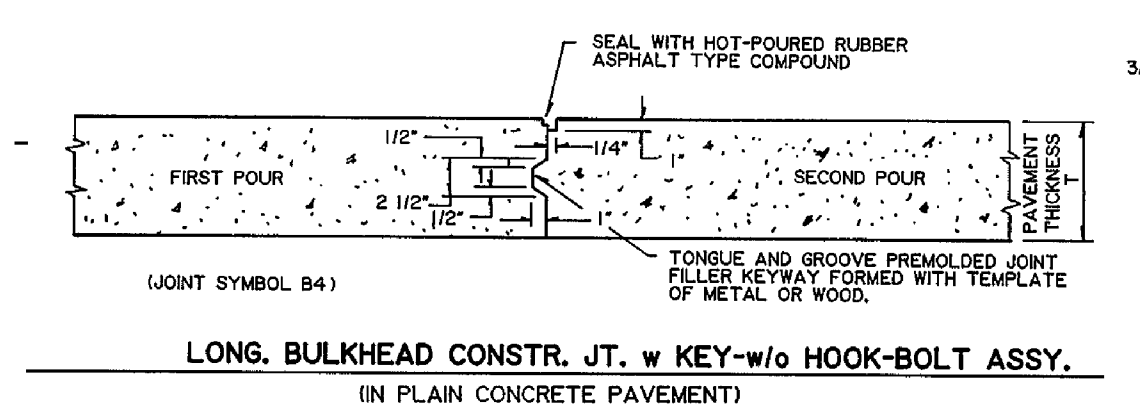

LONG. BULKHEAD CONSTR. JT. w KEY-W/O HOOK-BOLT ASSY.
(IN PLAIN CONCRETE PAVEMENT)

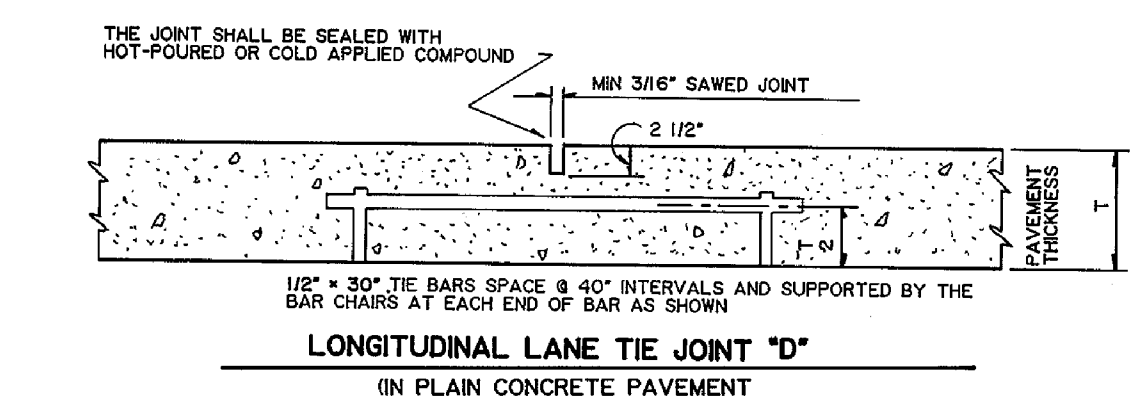

LONGITUDINAL LANE TIE JOINT "D"
(IN PLAIN CONCRETE PAVEMENT)

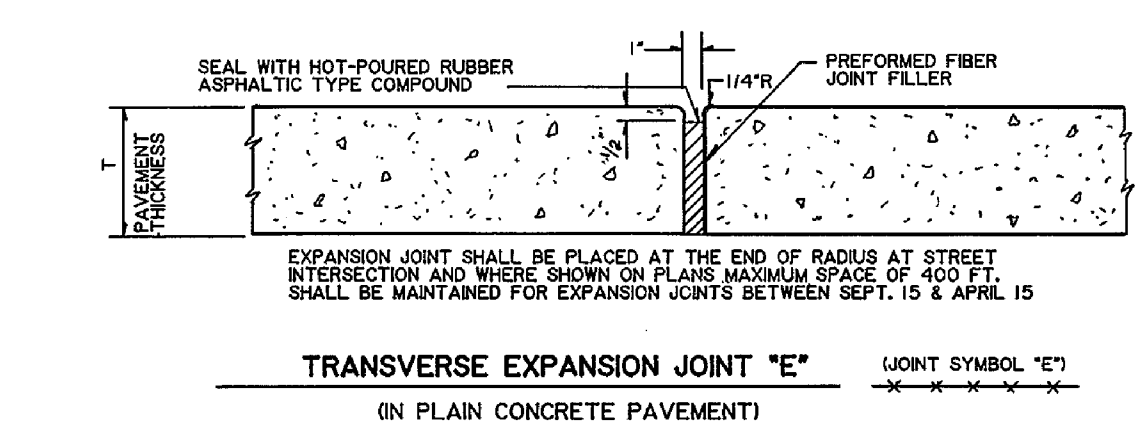

TRANSVERSE EXPANSION JOINT "E"
(IN PLAIN CONCRETE PAVEMENT)

EDGE WITH SHORT LIP EDGER. EDGE WITH LONG LIP EDGER.
TYPICAL
THE SEALING OF THIS JOINT WILL NOT BE REQUIRED WHEN IT IS USED IN BASE COURSE CONSTRUCTION.

FOR FUTURE PAVEMENT WIDENING THIS JOINT SHALL BE CONSTRUCTED ACCORDING TO THE DETAIL SHOWN EXCEPT THAT THE "SECOND POUR" AND THE "SECOND HALF" OF THE JOINT DOWEL HOOK BOLT SHALL BE OMITTED. THE THREADED HOLE IN THE HOOK BOLT COUPLING SHALL BE FILLED WITH A S. S. E-40 PETROLEUM BASE OIL AND PLUGGED WITH A PLASTIC OR NEOPRENE PLUG THE PLUG SHALL BE OF PROPER DIMENSION TO COMPLETELY SEAL THE HOLE AND SHALL NOT PROJECT MORE THAN 3/8" AFTER INSERTION.

TRANSVERSE WEAKENED PLANE JOINTS SHALL BE CONSTRUCTED IMMEDIATELY AFTER THE FINISHING OPERATION HAS BEEN COMPLETED A GROOVE SHALL BE FORMED IN THE PLASTIC CONCRETE WITH A METAL FORMING STRIP TO THE DEPTH SHOWN THE PREMOULDED FILLER STRIP SHALL BE PLACED IN THE GROOVE FORMED BY THE METAL STRIP FROM A BRIDGE OPERATING ON THE PAVEMENT FORMS THE CONCRETE SHALL BE HAND FLOATED AGAINST THE SIDES OF THE FILLER AND THE JOINT EDGED TO THE RADIUS SHOWN

TRANSVERSE WEAKENED PLANE JOINTS SHALL BE PLACED AT 20' INTERVALS BETWEEN TRANSVERSE EXPANSION JOINTS UNLESS OTHERWISE SHOWN ON PLANS.

TRANSVERSE CONSTRUCTION JOINTS SHALL BE PLACED AT ENDS OF ALL POURS AND WHERE PAVING OPERATIONS ARE DISCONTINUED FOR A PERIOD OF MORE THAN 20 MINUTES.

CONCRETE END HEADERS SHALL BE PLACED AT ALL ENDS OF PAVEMENT UNLESS OTHERWISE INDICATED ON THE PLANS. END HEADER WILL BE MEASURED BY AREA IN SQUARE YARDS AND WILL BE PAID FOR AT THE SAME UNIT PRICE BID PER SQUARE YARD AS FOR ADJACENT PAVEMENT.

JOINT SYMBOL
B=LONGITUDINAL BULKHEAD CONSTRUCTION JOINT
E=EXPANSION JOINT
D=LONGITUDINAL LANE TIE JOINT
WT=TRANSVERSE WEAKENED PLANE JOINT
B4=LONGITUDINAL BULKHEAD CONSTRUCTION JOINT WITH KEY.

CONCRETE END HEADER
CONCRETE END HEADERS SHALL BE PLACED AT ALL ENDS OF PAVEMENT UNLESS OTHERWISE INDICATED ON THE PLANS. NOT A PAY ITEM.

AGGREGATE STREET RETURN
AGGREGATE BASE 22A SHALL BE PLACED IN TWO UNIFORM LAYERS TO SUCH DEPTH THAT WHEN COMPACTED EACH LAYER WILL BE 3" IN THICKNESS EACH LAYER SHALL BE THOROUGHLY COMPACTED BY ROLLING WITH A PNEUMATIC-TIRED OR TAMPING TYPE ROLLER. NOT A PAY ITEM.

THE DITCHES AT STREET INTERSECTION SHALL BE CLEANED OUT AND RESHADED AS DIRECTED BY THE ENGINEER TO PROVIDE PROPER DRAINAGE THIS WORK WILL NOT BE A PAY ITEM

JOINT SYMBOL
B=LONGITUDINAL BULKHEAD CONSTRUCTION JOINT
E=EXPANSION JOINT
D=LONGITUDINAL LANE TIE JOINT
WT=TRANSVERSE WEAKENED PLANE JOINT
B4=LONGITUDINAL BULKHEAD CONSTRUCTION JOINT WITH KEY.

WHEN A STREET SIGN IS CALLED FOR ON THE PLAN IT SHALL BE PLACED ON THE N.E. CORNER OF THE INTERSECTION AT THE STANDARD LOCATION SHOWN. IF AN OBSTACLE INTERFERES WITH PLACING THE SIGN AT THE N.E. CORNER, IT SHALL BE PLACED AT THE S.W. CORNER IN THE SAME RELATIVE POSITION TO THE CURB AND WALK THE STREET SIGN ON STREETS INTERSECTING OR MEETING A "STOP HIGHWAY" SHALL BE PLACED AT THE STANDARD LOCATION ON THE RIGHT HAND SIDE OF THE STREET AS THE "STOP HIGHWAY" IS APPROACHED. ALSO IN THE CASE OF A "T" INTERSECTION THE SIGN SHALL BE PLACED ON THE RIGHT HAND SIDE OF THE STREET AS THE TOP LEG OF THE "T" IS APPROACHED.

SIGN SPECIFICATIONS

- SIGN PANELS:** SIZE 6" x 24" OR 6" x 30" DEPENDING ON LENGTH OF LEGEND
 - MATERIAL:** NO. 6061-T6 ALUMINUM (063 GAUGE)
 - INSCRIPTION:** 4" BLACK ROUND BLOCK TYPE LETTERS ON WHITE OR SILVER BACKGROUND, REFLECTORIZED AND WITHOUT A BORDER.
 - POST:** GALVANIZED SQUARE TUBING WITH CONTINUOUS 7/16 DIA. HOLES ON 1" CENTERS, ALL 4 SIDES, ENTIRE LENGTH UNISTRUT OR APPROVED EQUAL.
- FOR SIGN LOCATION SEE APPROACH SIDEWALK DETAIL

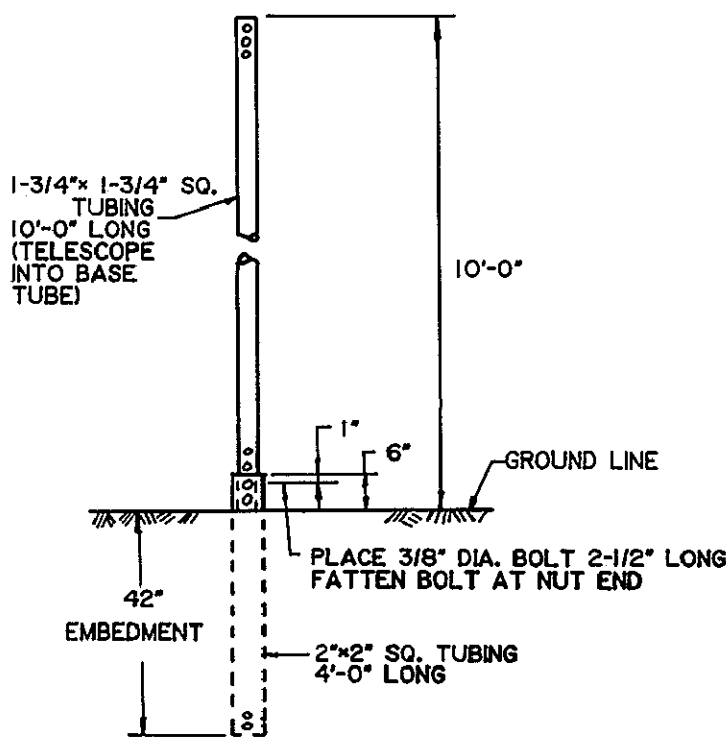

DETAIL OF POST

CURVED END PANELS (FOR TWO-WAY TRAFFIC) SHALL BE USED AT BOTH ENDS OF THE GUARD RAIL SECTION WHEN THE GUARD RAIL IS PLACED PARALLEL TO PAVEMENT AT OTHER LOCATIONS USE STRAIGHT END PANEL.

SPLICED BOLT L = 11/4-8 REQUIRED PER SPLICE
WOOD POST BOLT L = 5/4-1 REQUIRED (WITH WASHER) PER POST
STEEL POST BOLT L = 2-1 REQUIRED PER POST

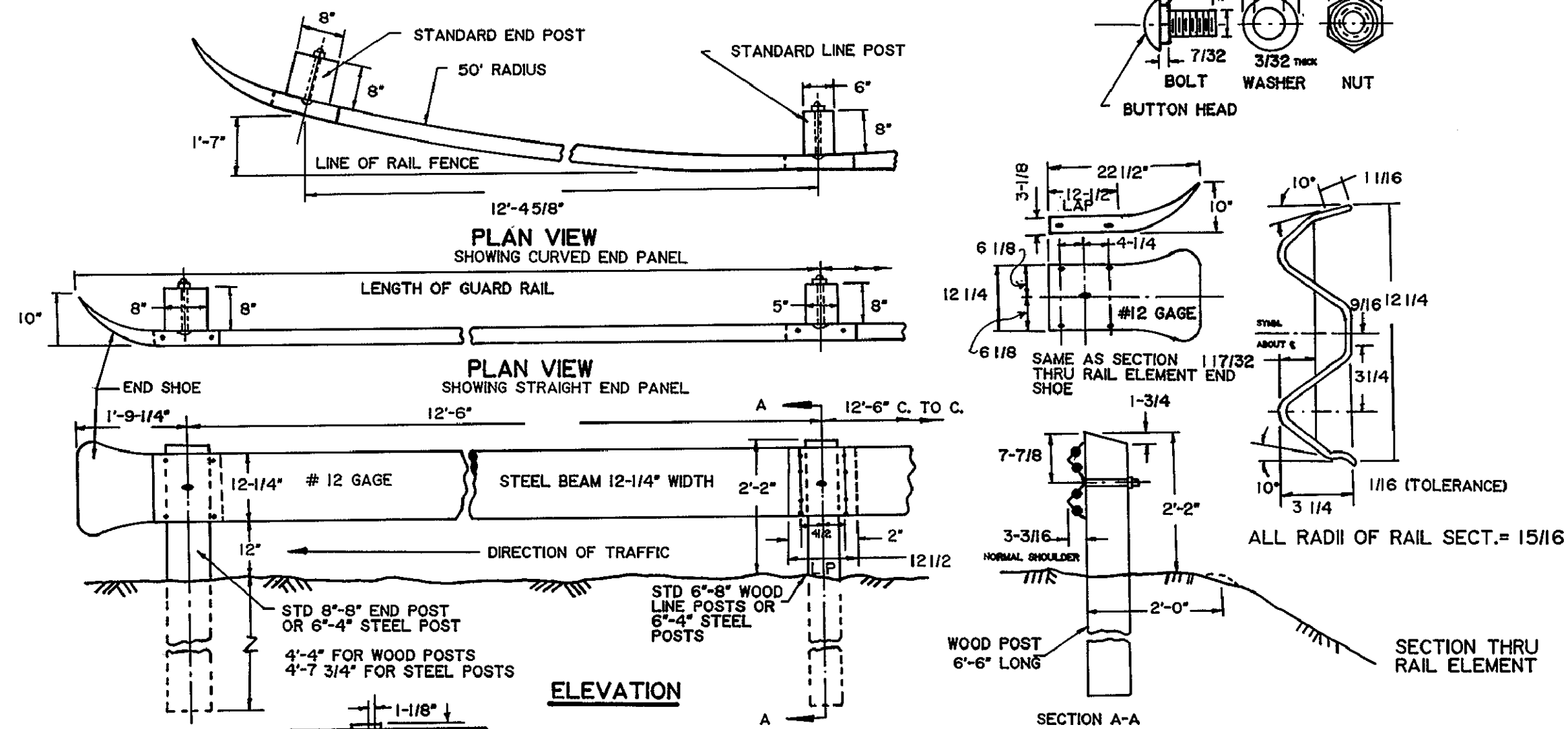

NOTE
STEEL POSTS OF LENGTH SHOWN MAY BE SUBSTITUTED IN PLACE OF WOOD POSTS AND SHALL BE IN ACCORDANCE WITH THE SPECIFICATION.

STEEL BEAM GUARD RAIL

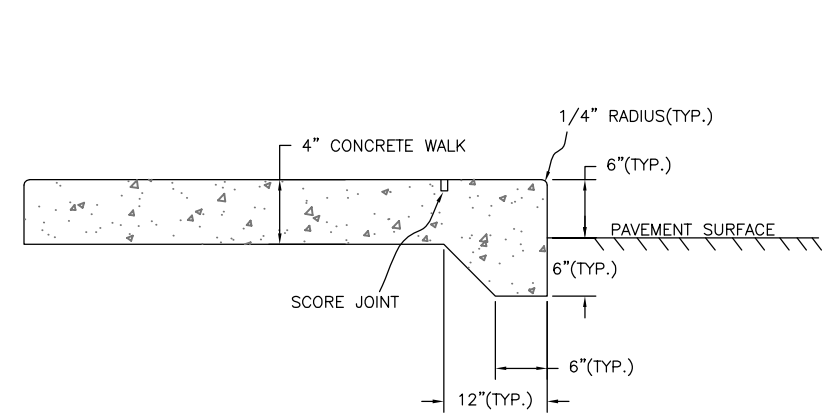

THICKENED EDGE CONCRETE WALK DETAIL

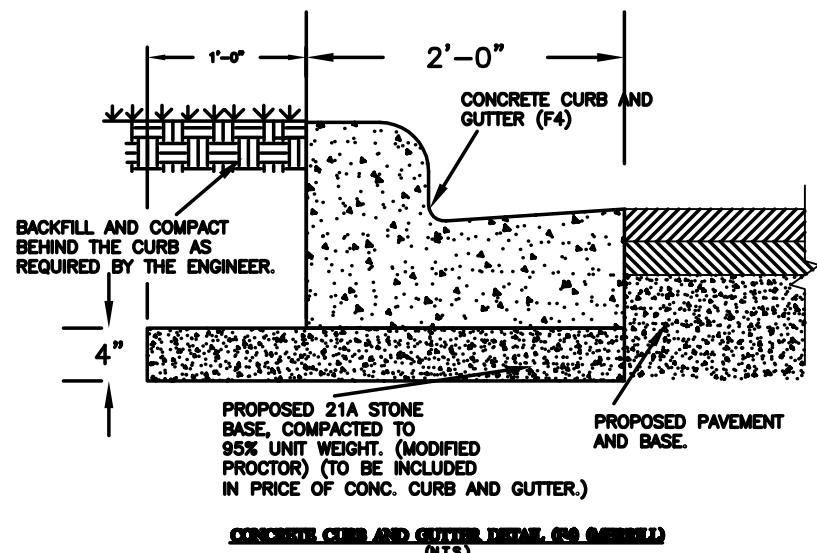

PROPOSED 2 1/4\"/>

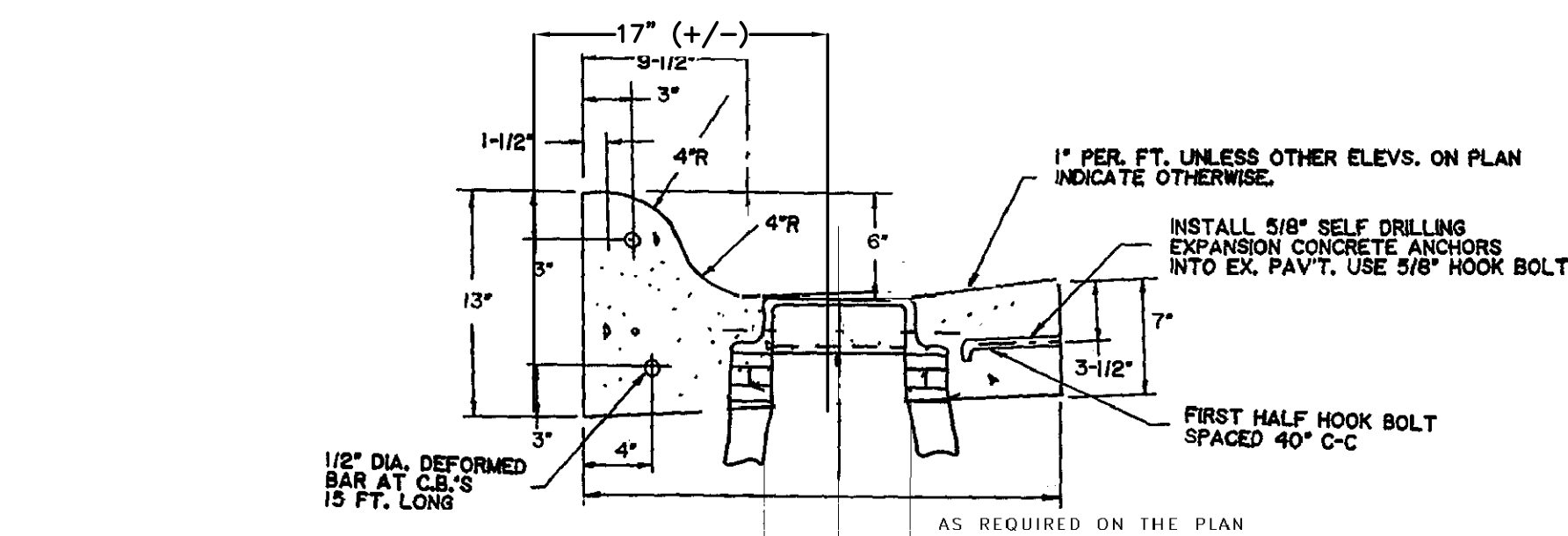

CURB AND GUTTER

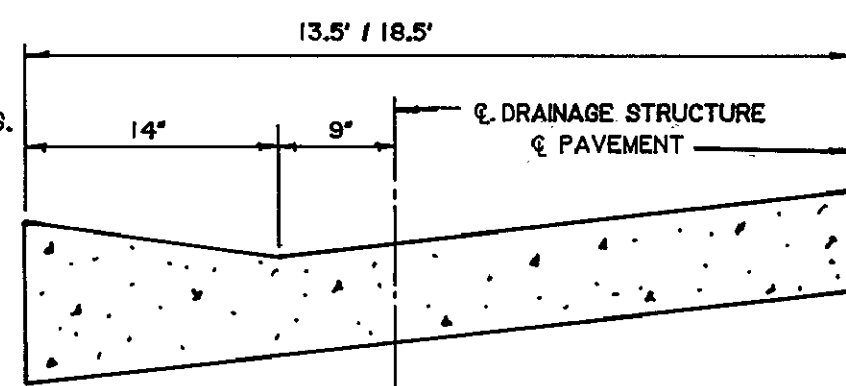

LOCATION OF DRAINAGE STRUCTURE AT MOUNTABLE 4\"/>

EXPANSION JOINTS SHALL BE PLACED 10' EACH SIDE OF ALL CATCH BASINS AND AT THE ENDS OF RADI AT ALL STREET RETURNS AND SEALED WITH HOT-POURED RUBBER ASPHALT COMPOUND. PLANE OF WEAKNESS JOINTS SHALL BE PLACED BETWEEN EXPANSION JOINTS AT APPROXIMATELY 10' INTERVALS BY THE USE OF FULL DEPTH 1/8\"/>

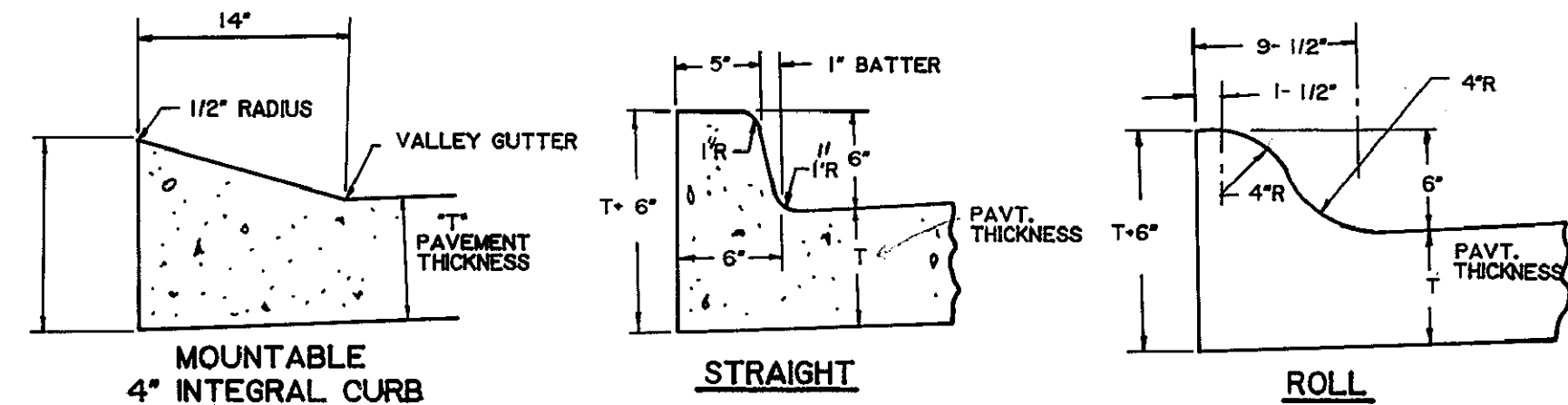
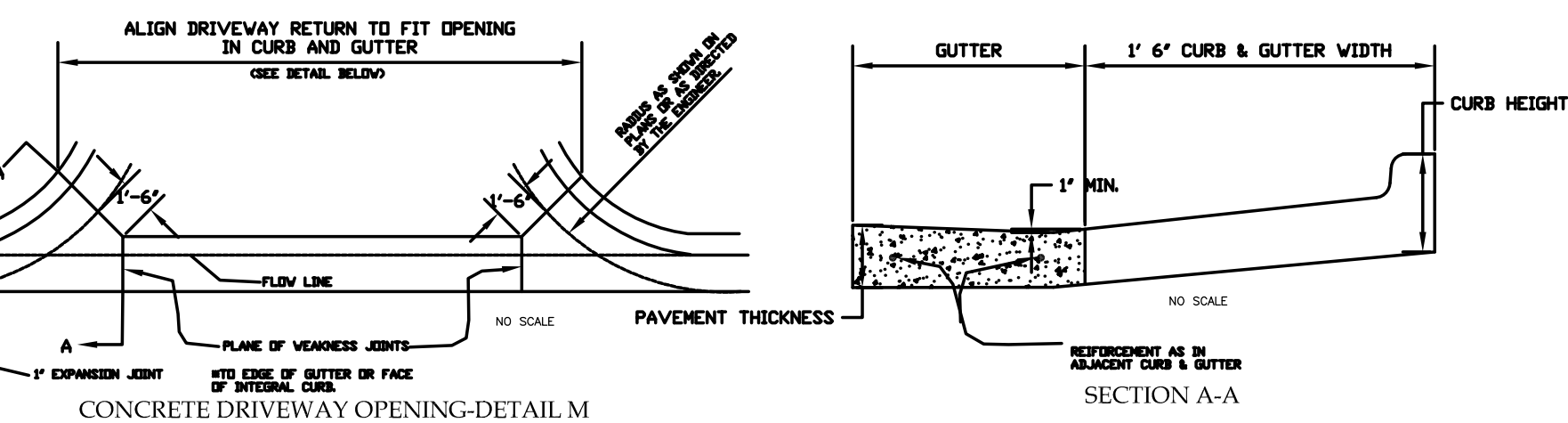
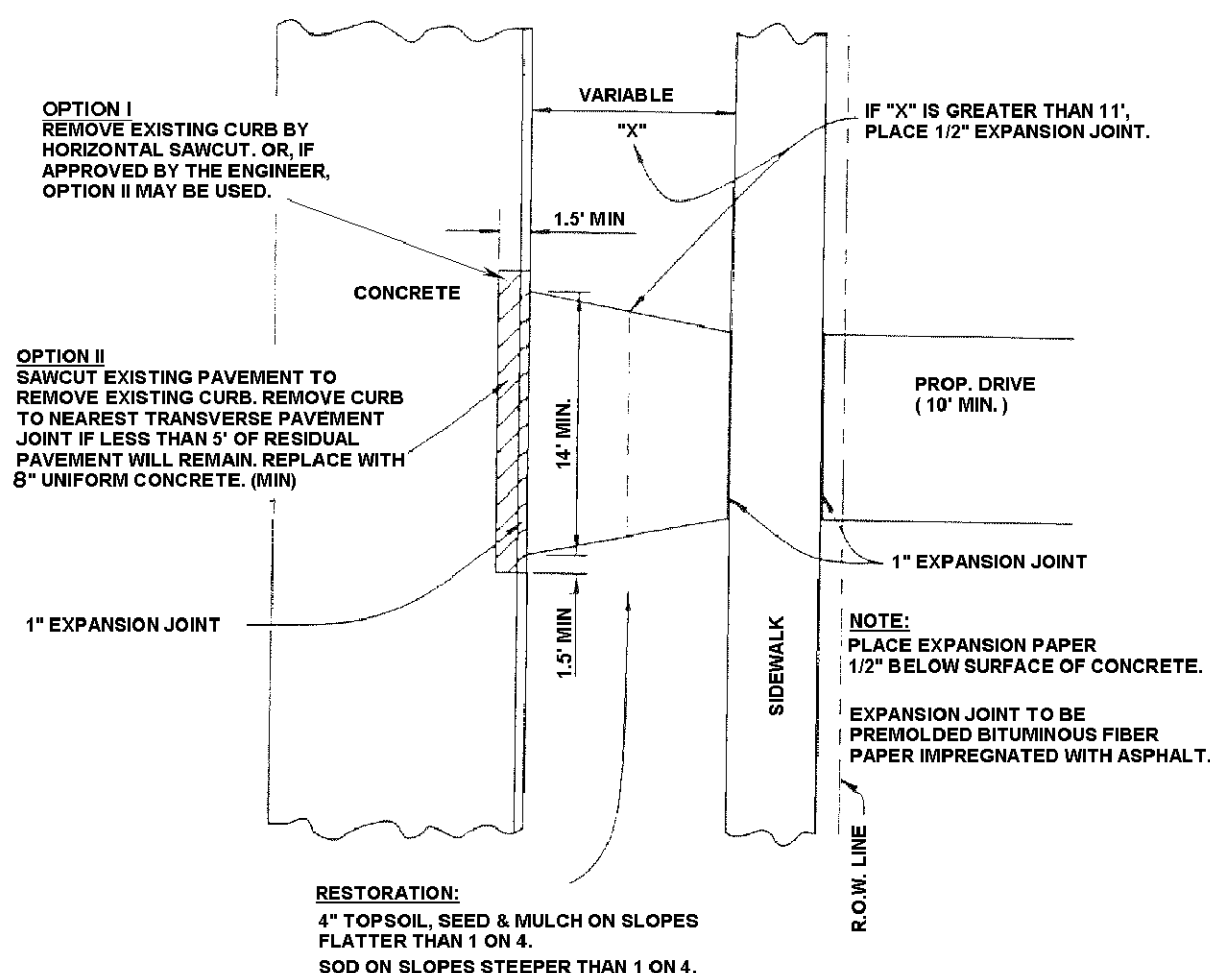

NOTE

TRANSVERSE EXPANSION AND WEAKENED PLANE JOINT IN PAVEMENT SHALL EXTEND ENTIRELY THROUGH INTEGRAL CURB AND SHALL BE OF THE SAME THICKNESS AND KIND AS PROVIDED FOR THE PAVEMENT. THE JOINT MATERIAL SHALL BE PRECUT SO AS TO CONFORM TO THE GEOMETRIC SHAPE AND CROSS-SECTION AREA OF THE CURB AND SHALL BE PLACED IN CONTACT WITH THE FILLER MATERIAL IN THE PAVEMENT. STRAIGHT CURB SHALL BE USED AT ALL PRIMARY ROAD INTERSECTIONS. FACE FORMS SHALL BE USED TO FORM STRAIGHT CURB. STEEL TEMPLATE SHALL BE USED TO FORM THE ROLL CURB AND MOUNTABLE CURB.

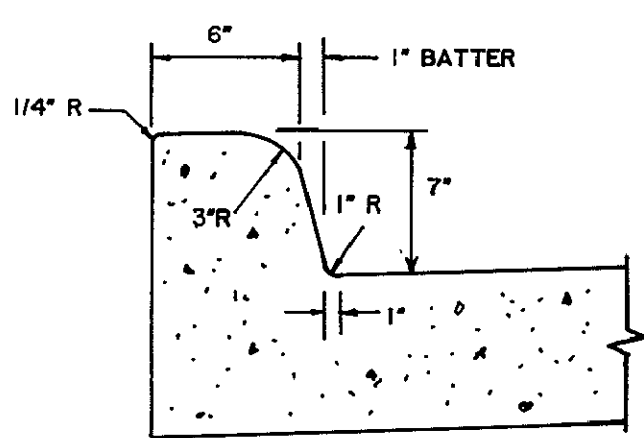

7\"/>

A 1\"/>

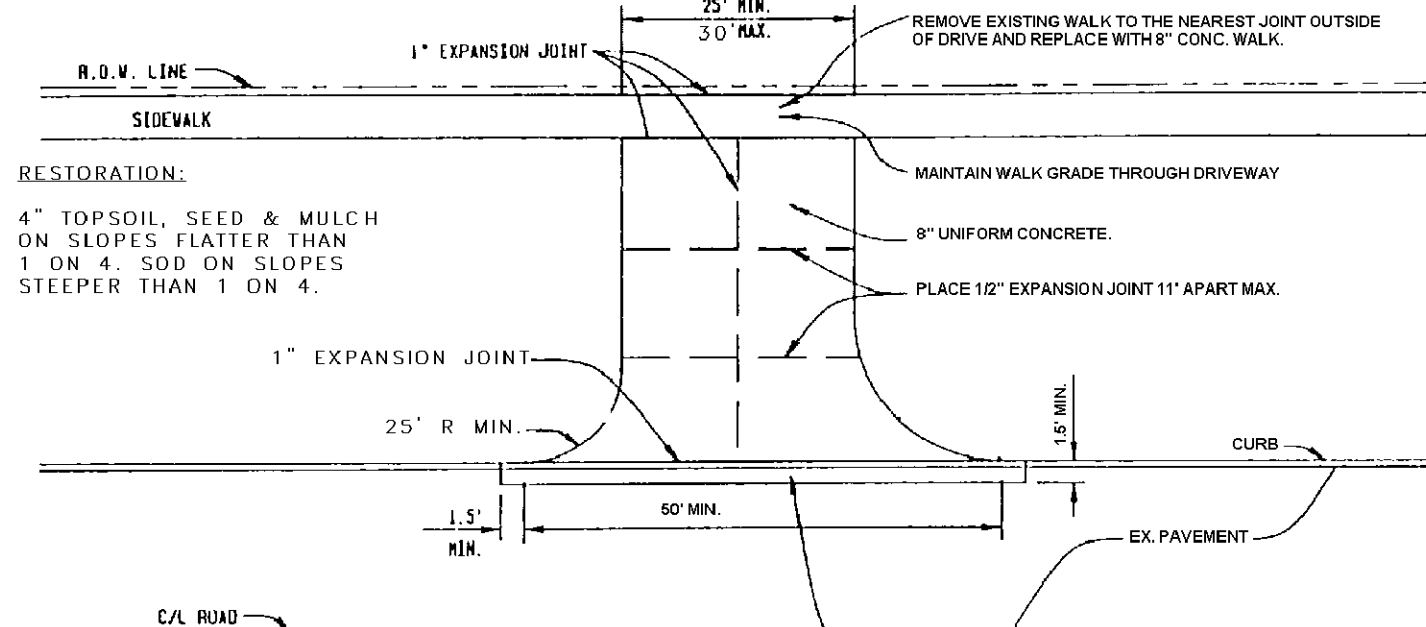

NOTE:
PLACE EXPANSION PAPER 1/2\"/>

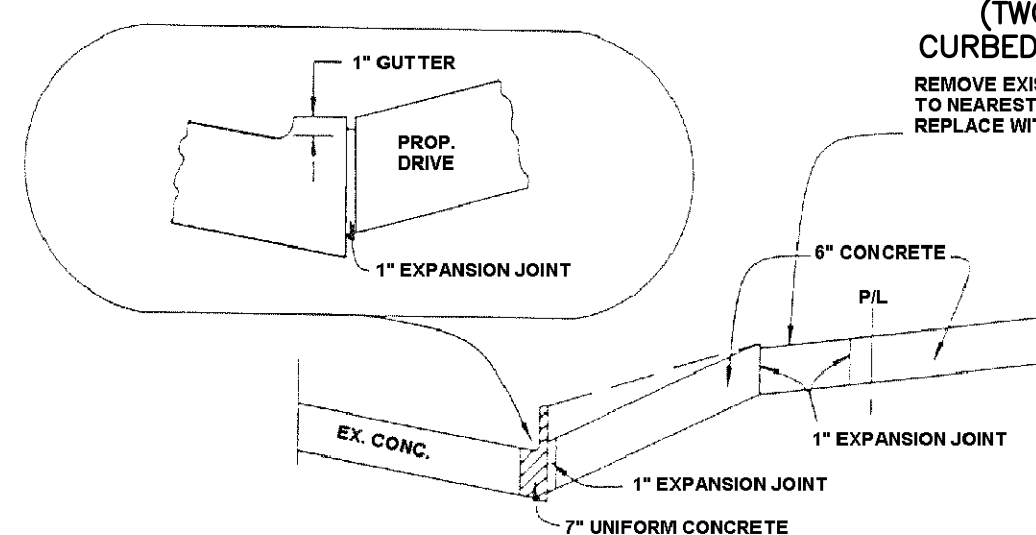

RESIDENTIAL CONCRETE DRIVEWAY CURBED PAVEMENT

PROJECT NUMBER: 76307
DATE: 07/1/08
SCALE: NTS
DESIGNED BY: ZJ
DRAWN BY: NKA
CHECKED BY:
APPROVED BY:

REVISIONS

ENGINEERING THE FUTURE.
13500 REECK ROAD
SOUTHGATE, MI 48195
(734) 759-1600
FAX (734) 282-6566
WWW.HENGINEERS.COM

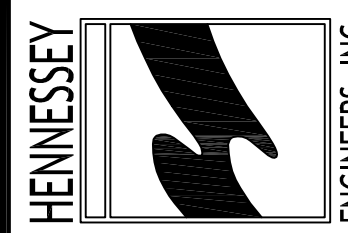

TITLE: PAVING DETAILS
CITY OF ECORSE
WAYNE COUNTY, MICHIGAN

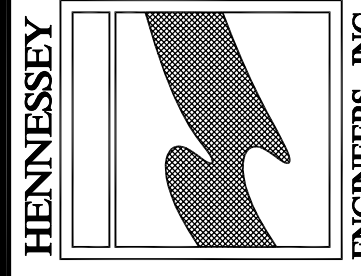

SEWER SIZE	MAX. CUT OUT SIZE
8" THRU 10"	17 1/2"
12" THRU 15"	20"

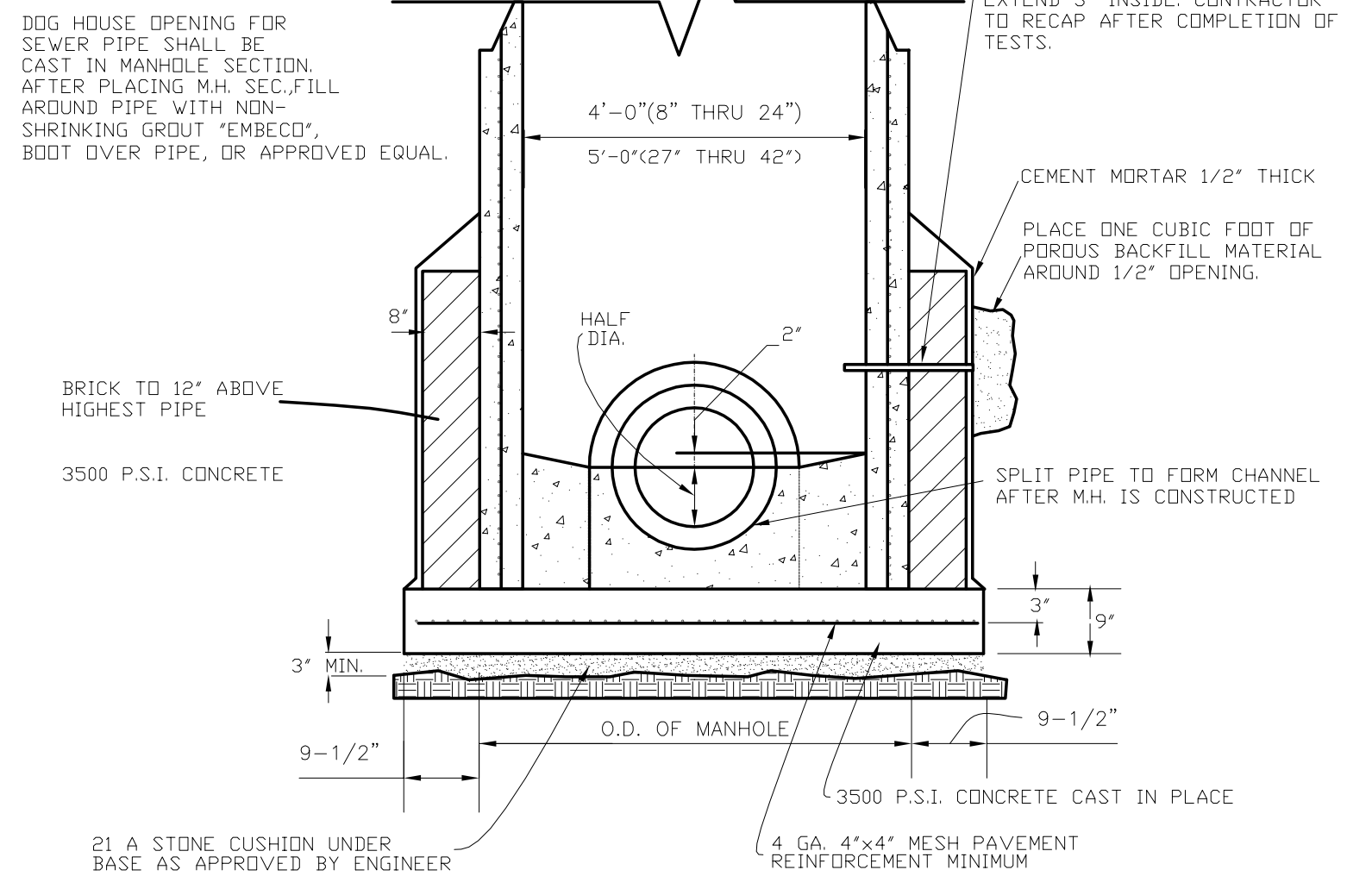

STANDARD SANITARY MANHOLE
ON EXISTING SEWERS 8" THROUGH 42"

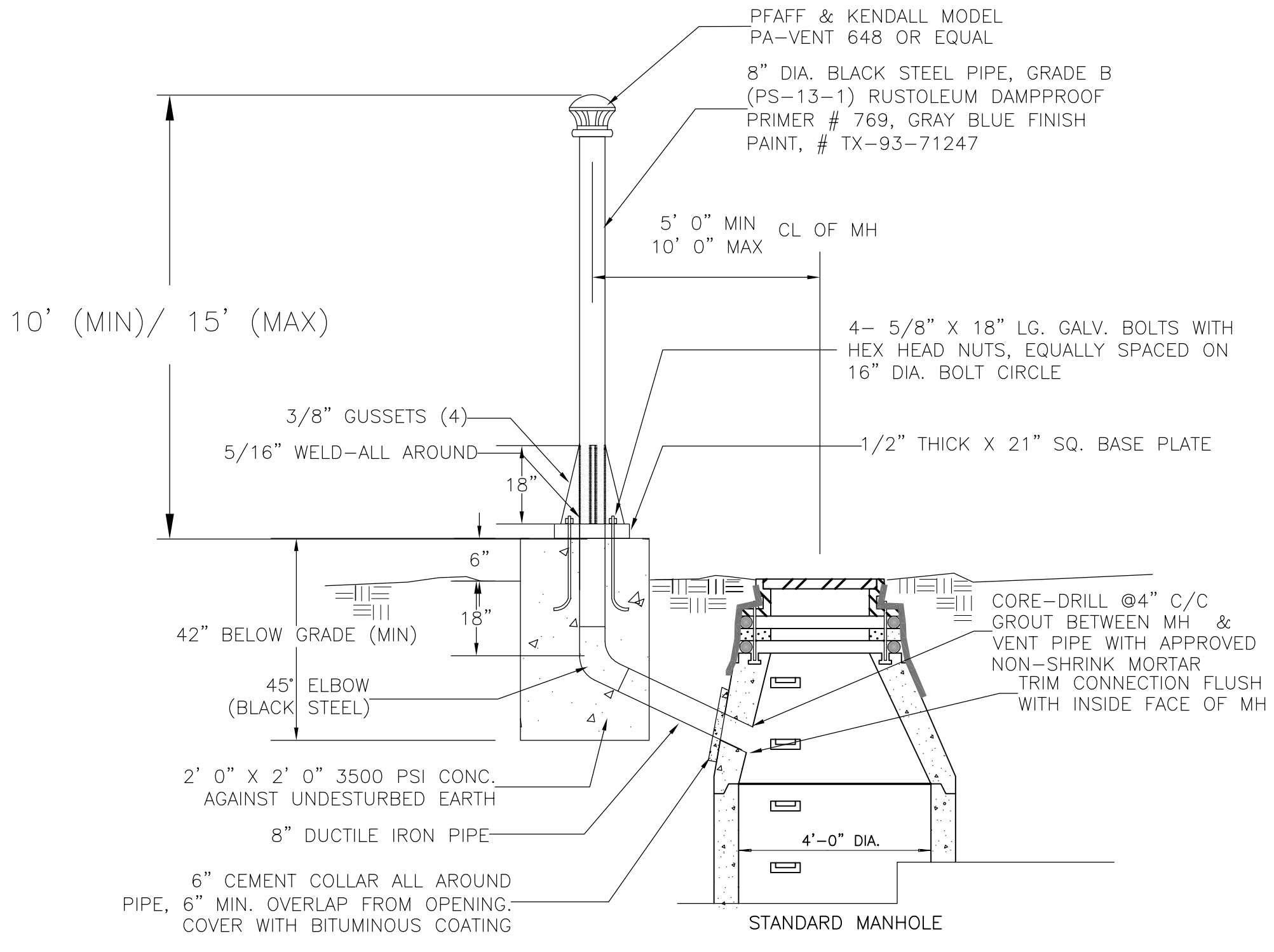

STANDARD VENT ASSEMBLY

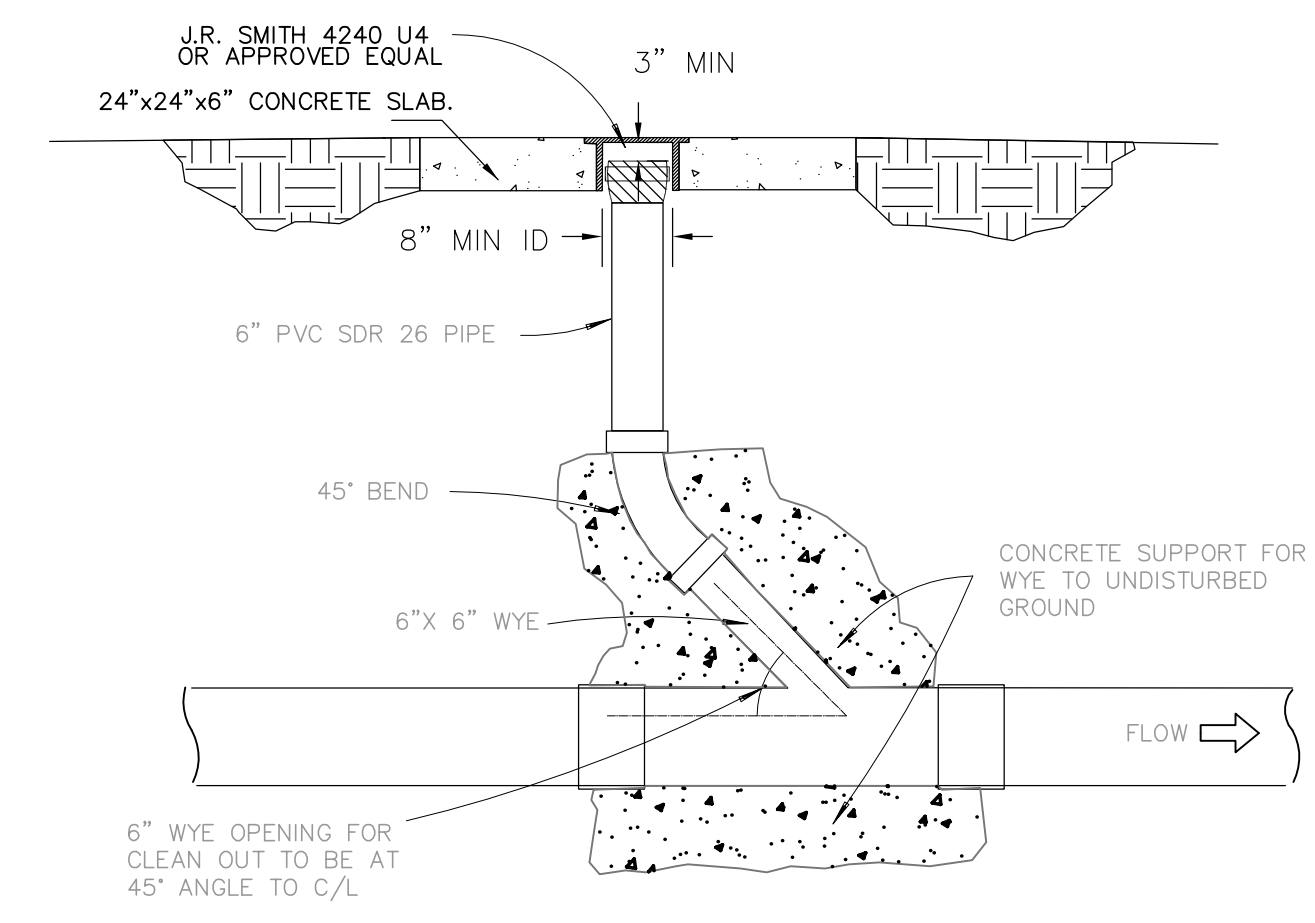

DETAIL OF SANITARY SEWER CLEANOUT

NOTE:

CONCRETE RINGS - 1/2" MORTAR COATING INSIDE AND OUT.
EJIW 1040-A, 2 REQUIRED
SLOPE FINISH GRADE AWAY FROM COVERS
"WRAPID SEAL", (CANUSA WRAP) MANHOLE ENCAPSULATION SYSTEM OR APPROVED EQUAL EXTERNAL SEAL
BASE TANK IS 1000 GAL. DOUBLE COMPARTMENT SEPTIC TANK. CONCRETE THICKNESS, TYPE AND REINFORCEMENT ARE PER MFR. LIGHT DUTY OR TRAFFIC LOADING PER PLAN.

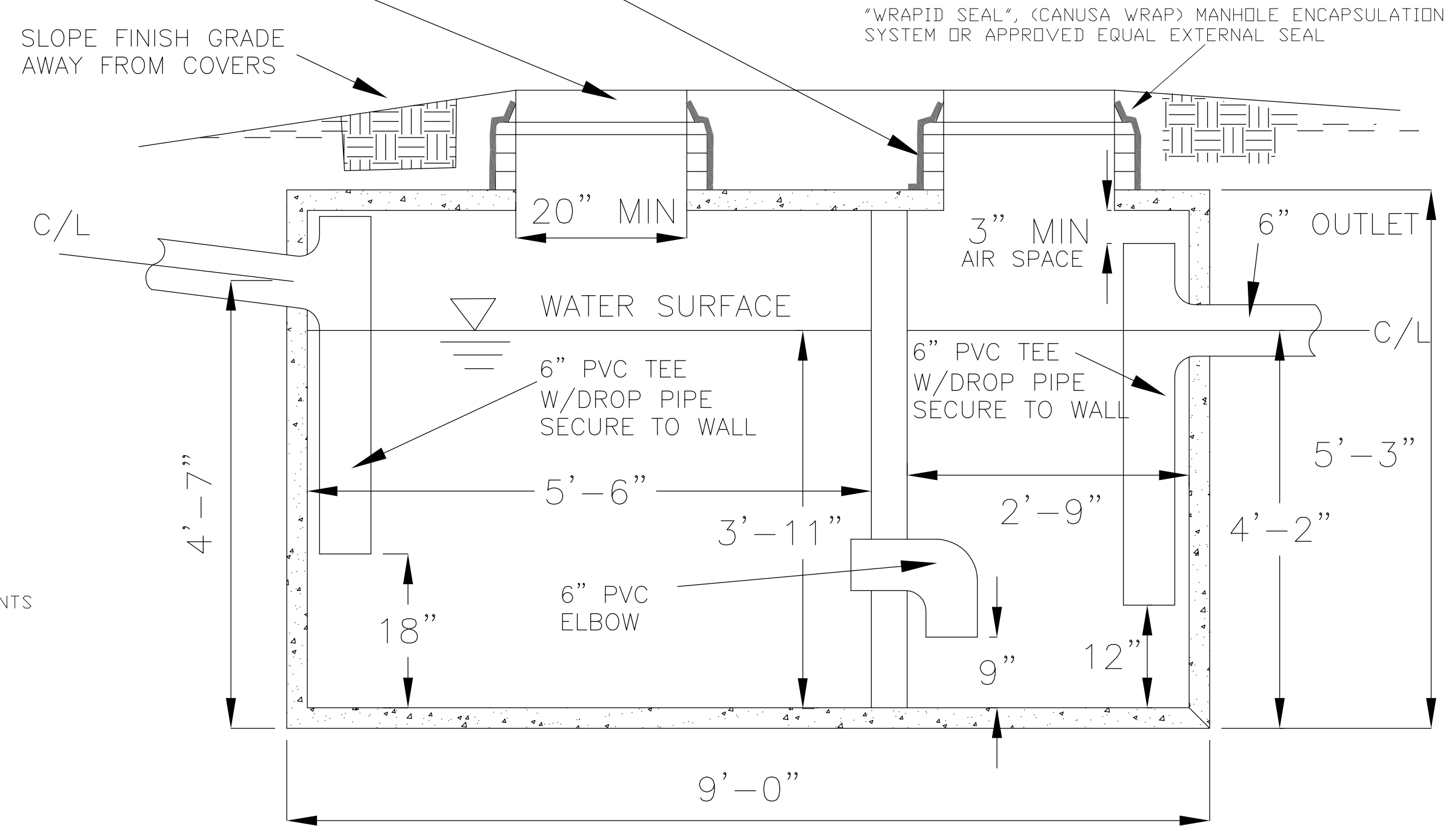

OIL AND GREASE INTERCEPTOR
(NOT TO SCALE)

"WRAPID SEAL", (CANUSA WRAP) MANHOLE ENCAPSULATION SYSTEM OR APPROVED EQUAL EXTERNAL SEAL

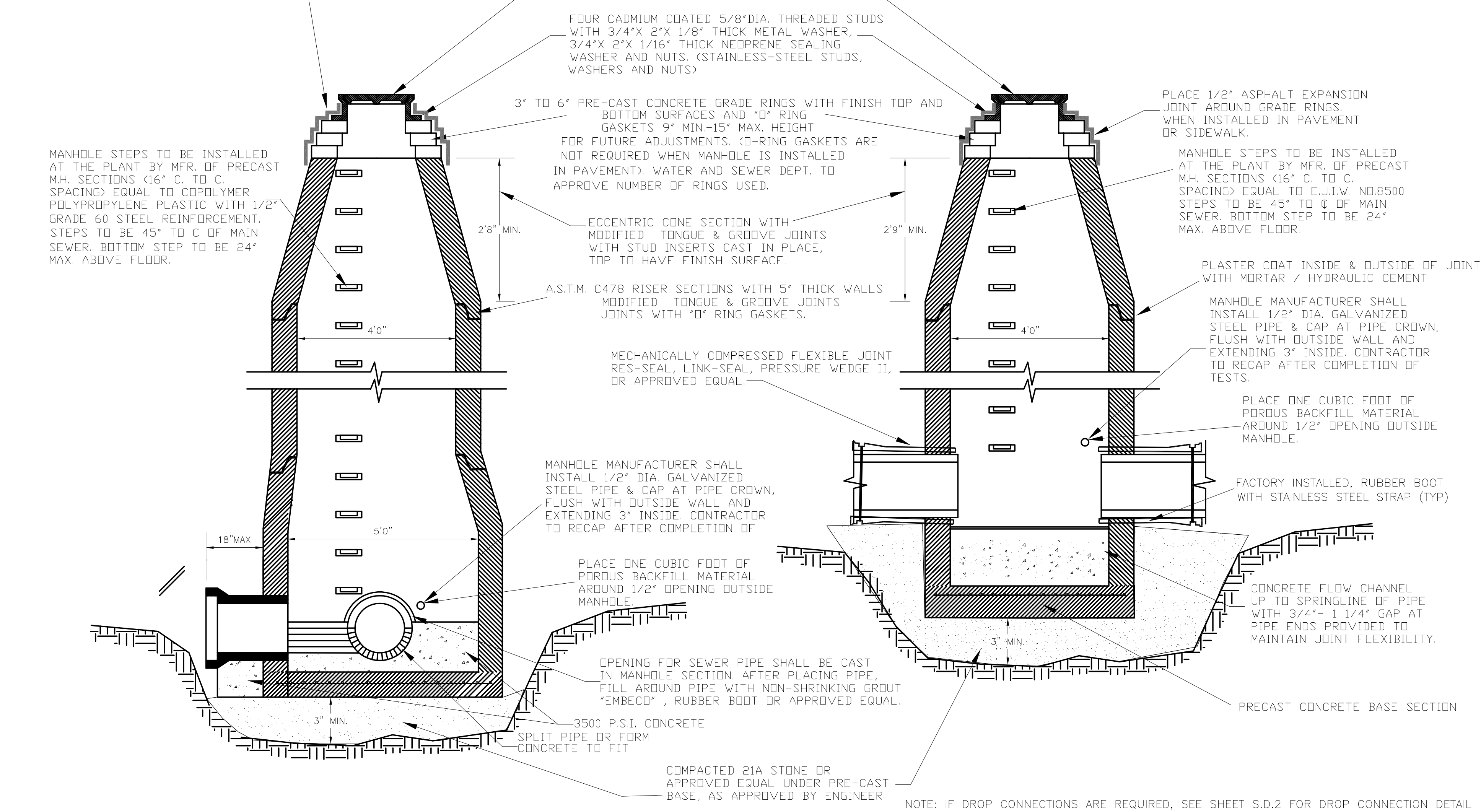

STANDARD SANITARY MANHOLE
FOR SEWERS 27" THROUGH 42"

STANDARD SANITARY MANHOLE
FOR SEWERS 8" THROUGH 24"

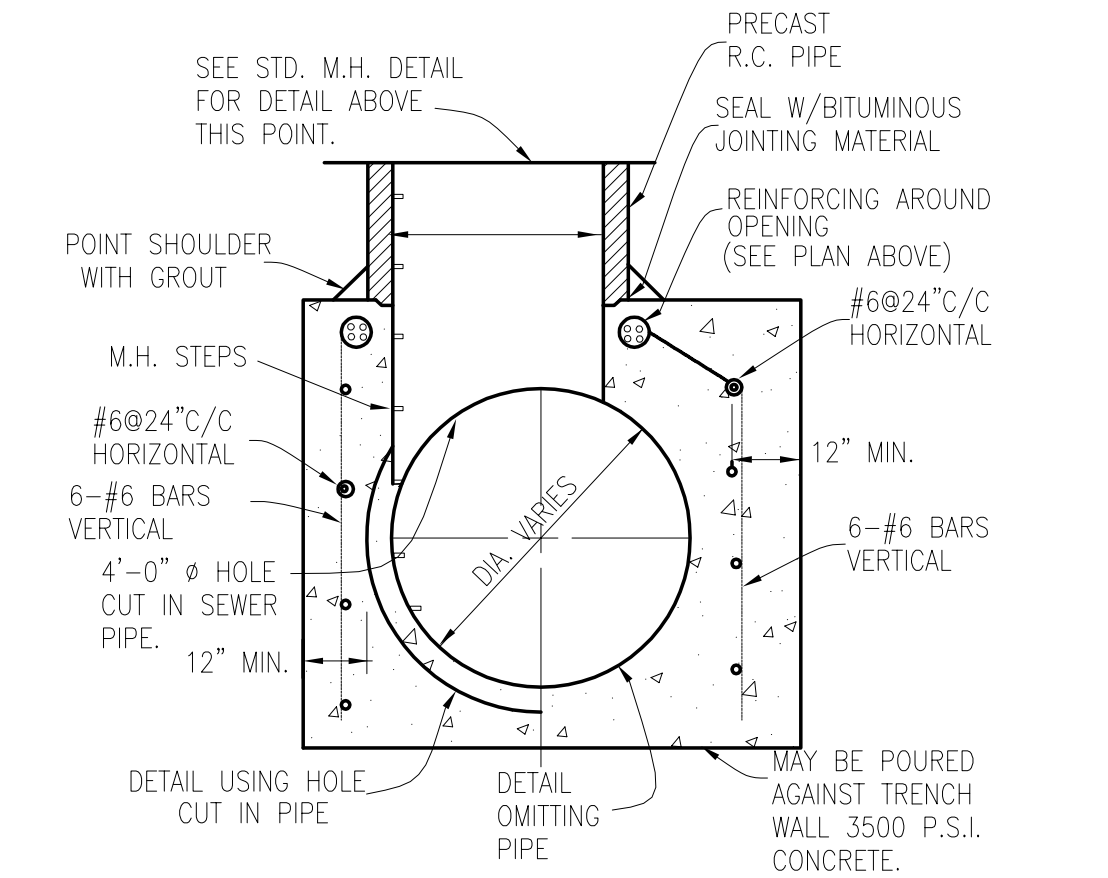

MANHOLE SECTION A-A
48" & LARGER SEWERS

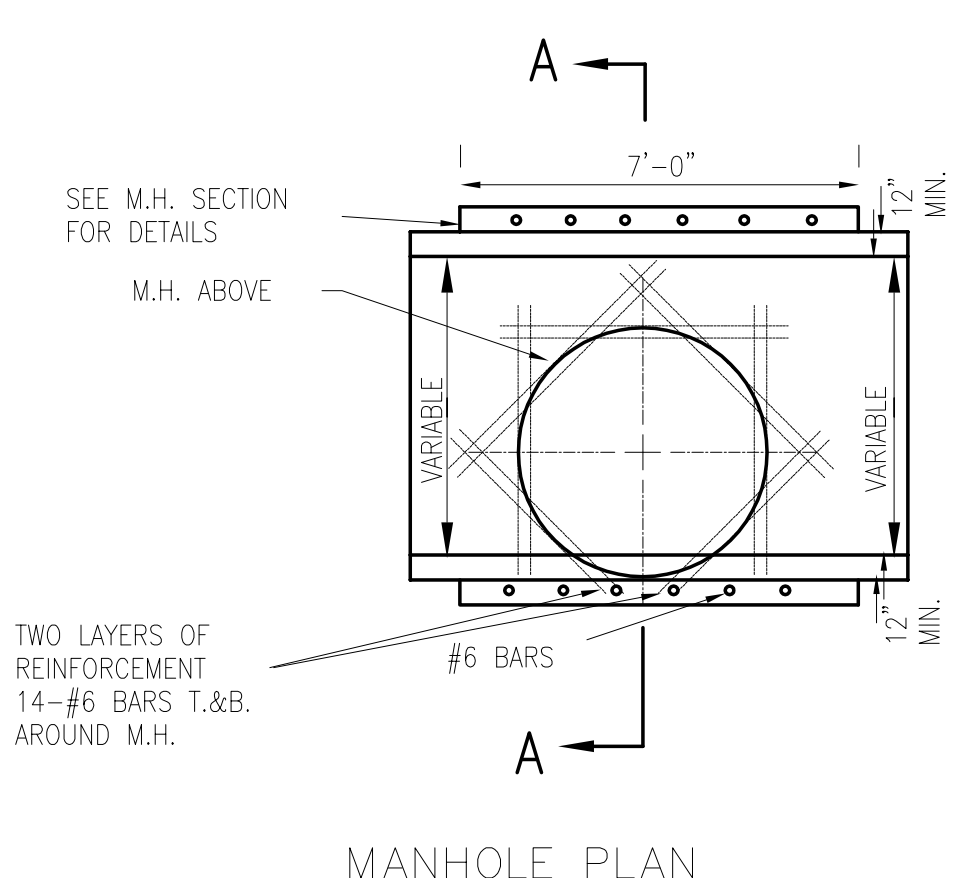

MANHOLE PLAN
48" & LARGER SEWERS

NOTE: IF DROP CONNECTIONS ARE REQUIRED, SEE SHEET S.D.2 FOR DROP CONNECTION DETAIL

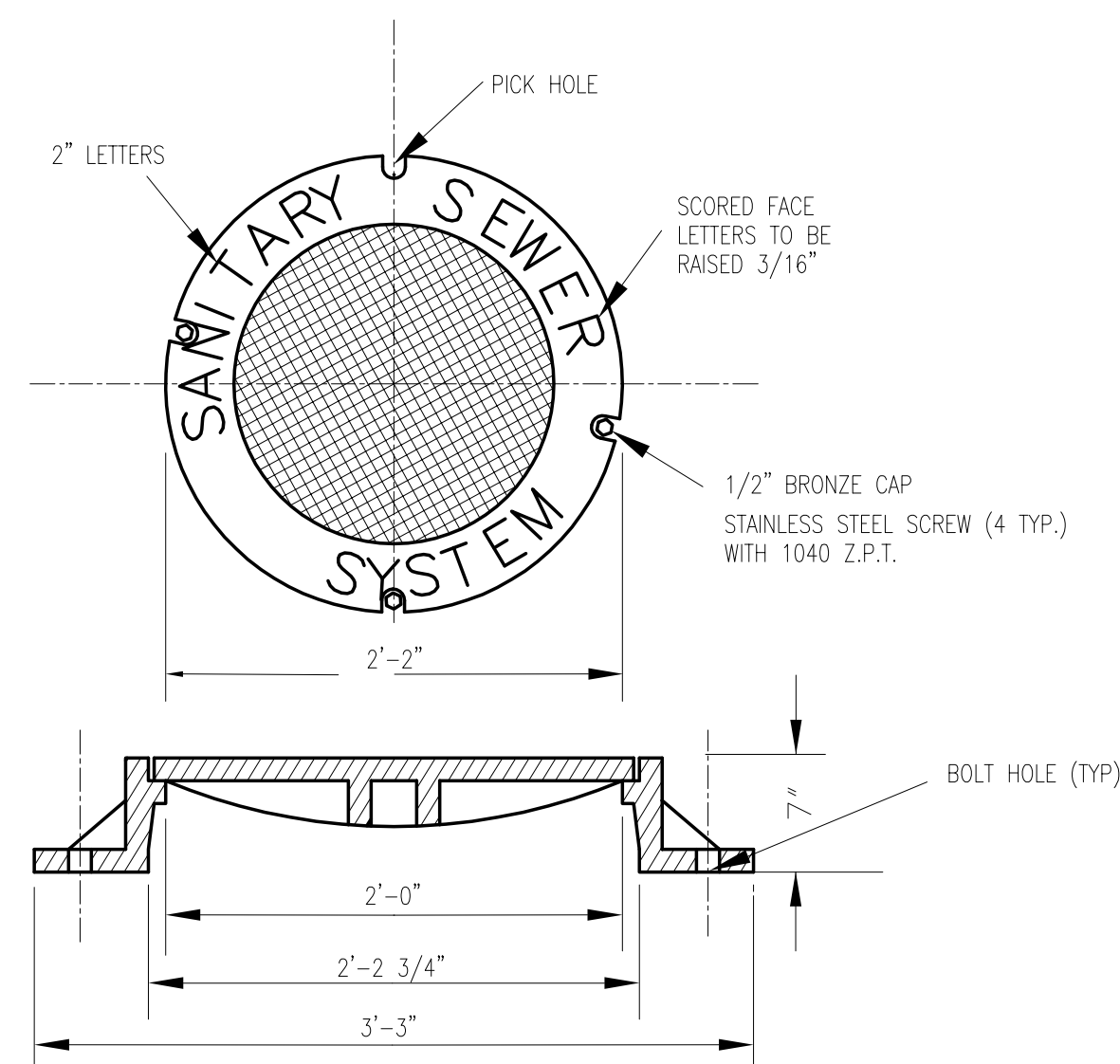

STANDARD FRAME AND COVER
 "ECORSE" IMPRINT
 E.J.I.W. #1040 ZPT OR APPROVED EQUAL

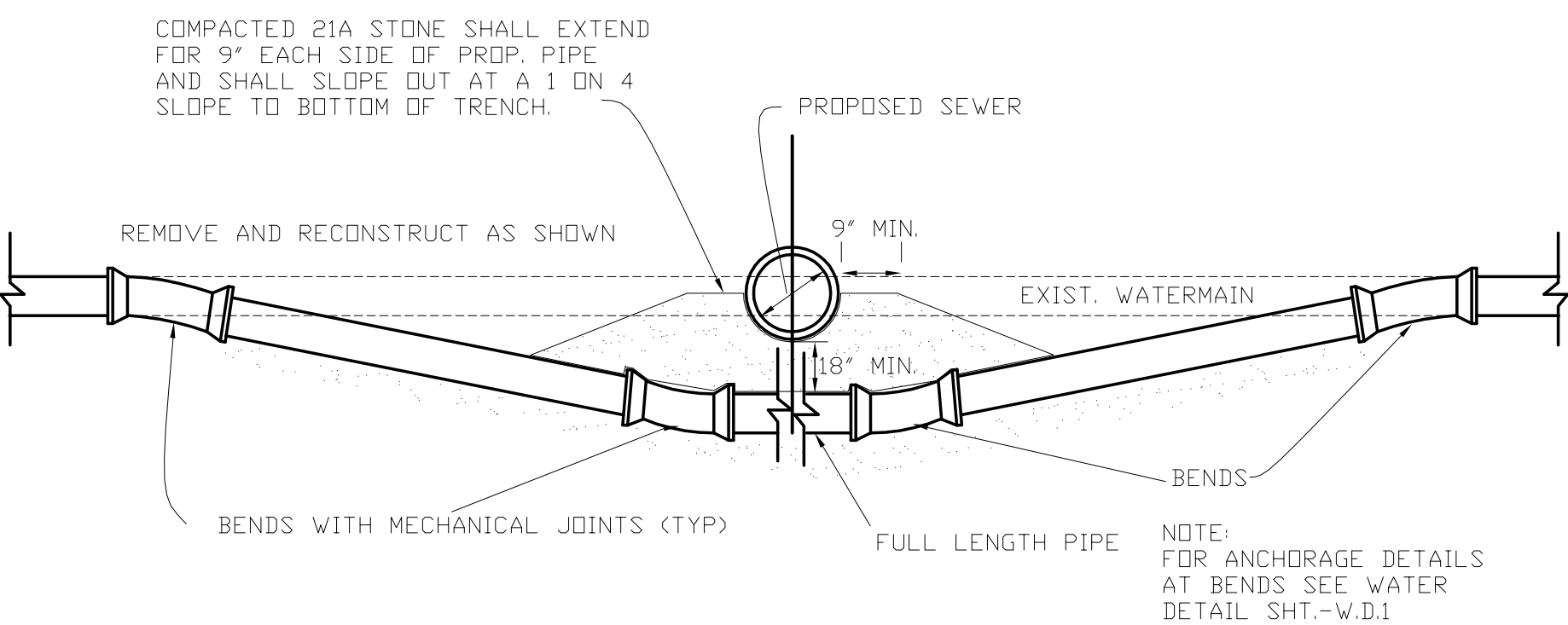

RELOCATION OF WATERMAIN

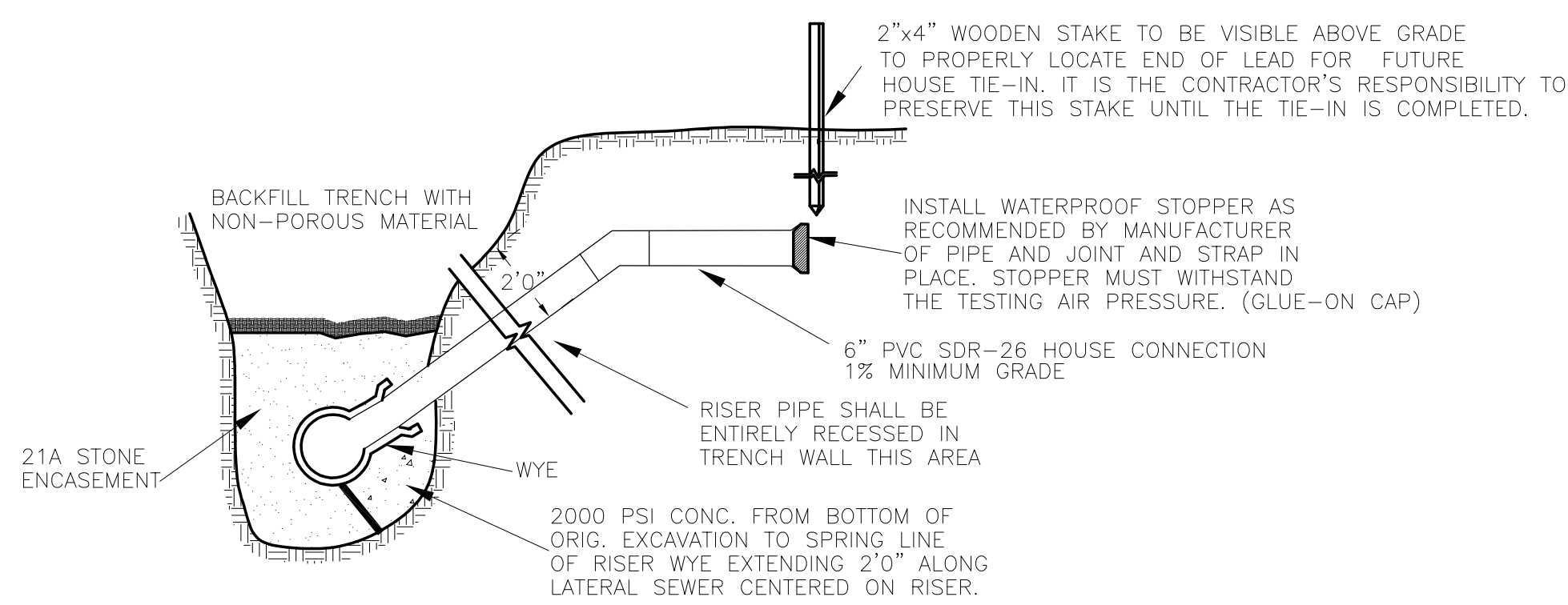

RISER DETAIL

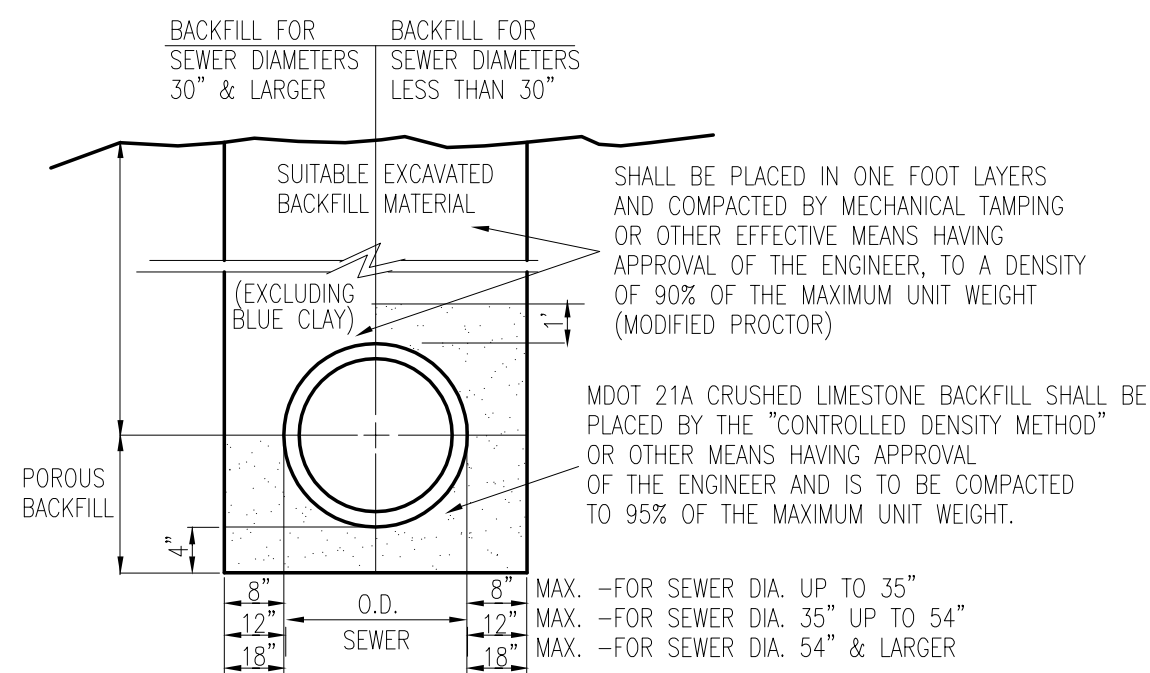

SEWER TRENCH "A"

NOTE:
 PVC PIPE:
 MIN. TRENCH WIDTH = 1.5 X O.D. + 12" (FOR ALL INSTALLATION DEPTHS)
 (O.D. = OUTSIDE DIAMETER OF PIPE.)

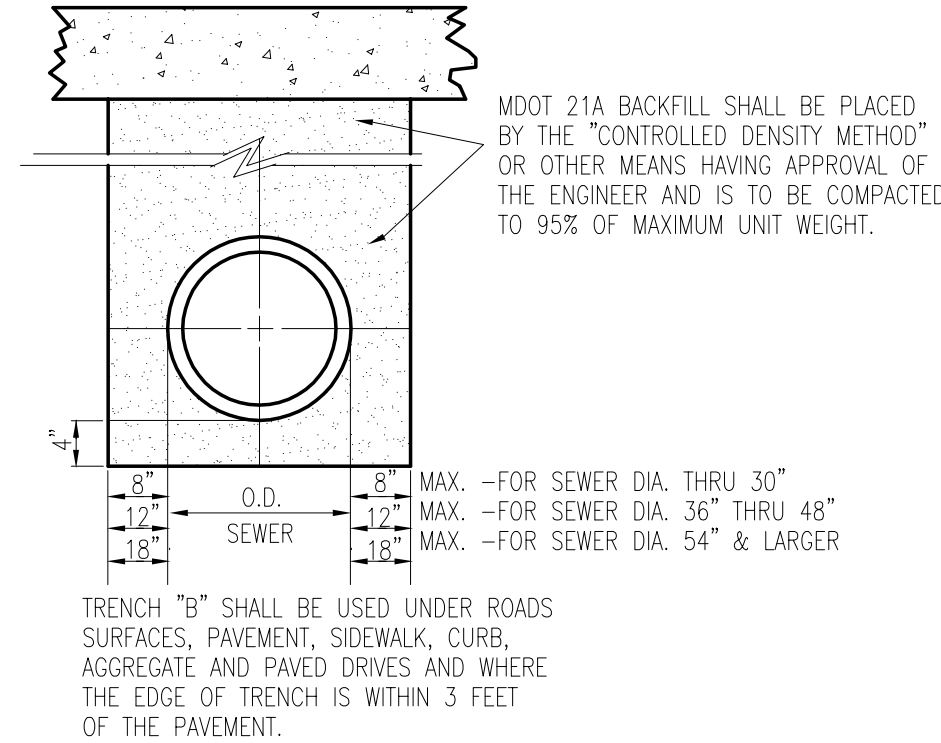

SEWER TRENCH "B"

NOTE:
 PVC PIPE:
 MIN. TRENCH WIDTH = 1.5 X O.D. + 12" (FOR ALL INSTALLATION DEPTHS)
 (O.D. = OUTSIDE DIAMETER OF PIPE.)

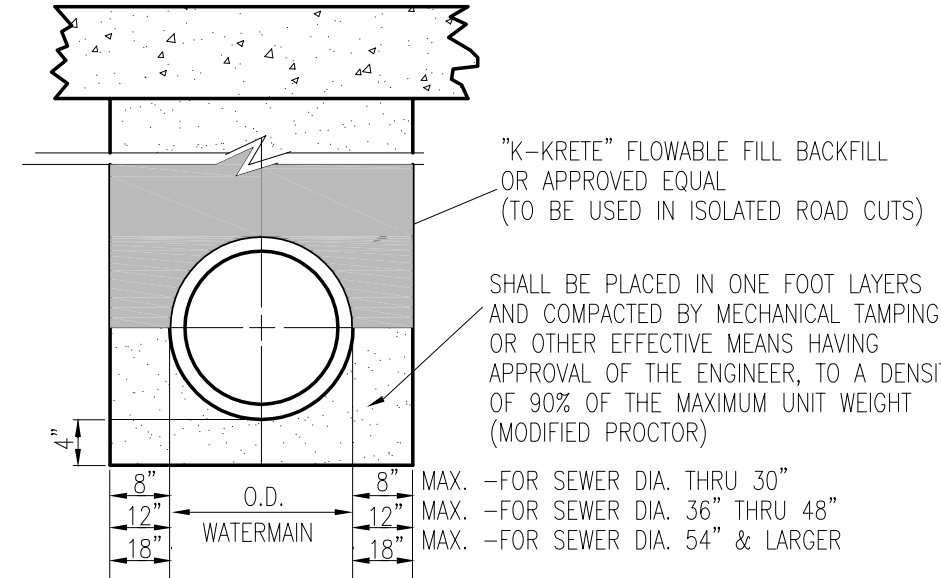

SEWER TRENCH "C"

NOTE:
 PVC PIPE:
 MIN. TRENCH WIDTH = 1.5 X O.D. + 12" (FOR ALL INSTALLATION DEPTHS)
 (O.D. = OUTSIDE DIAMETER OF PIPE.)

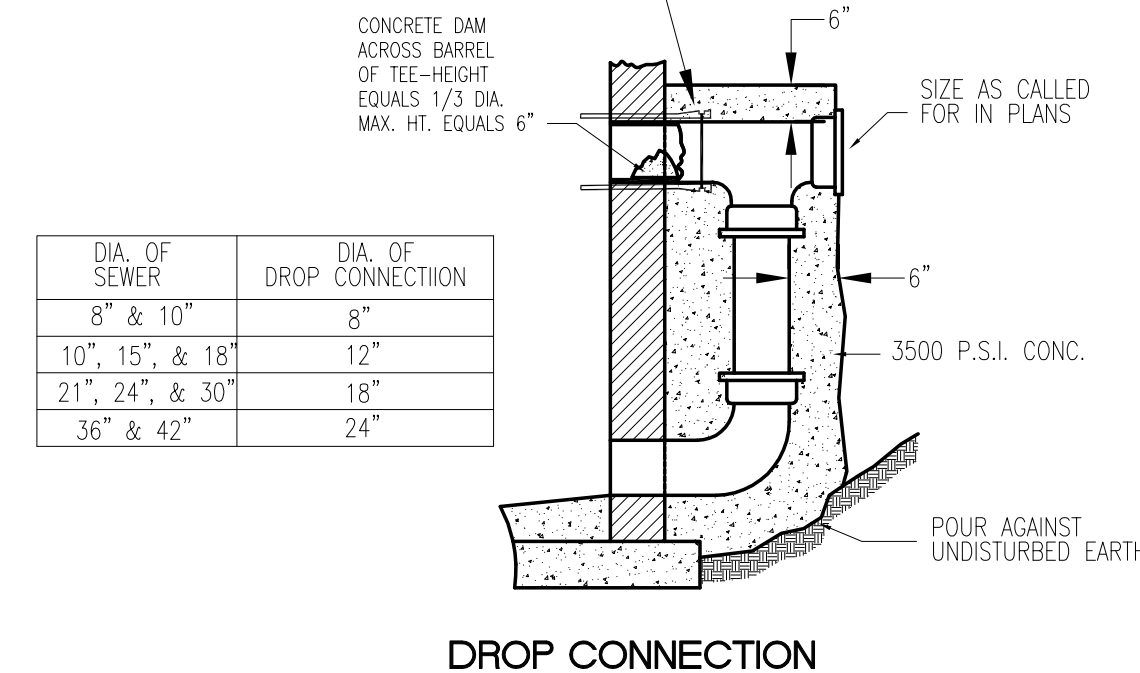

DROP CONNECTION

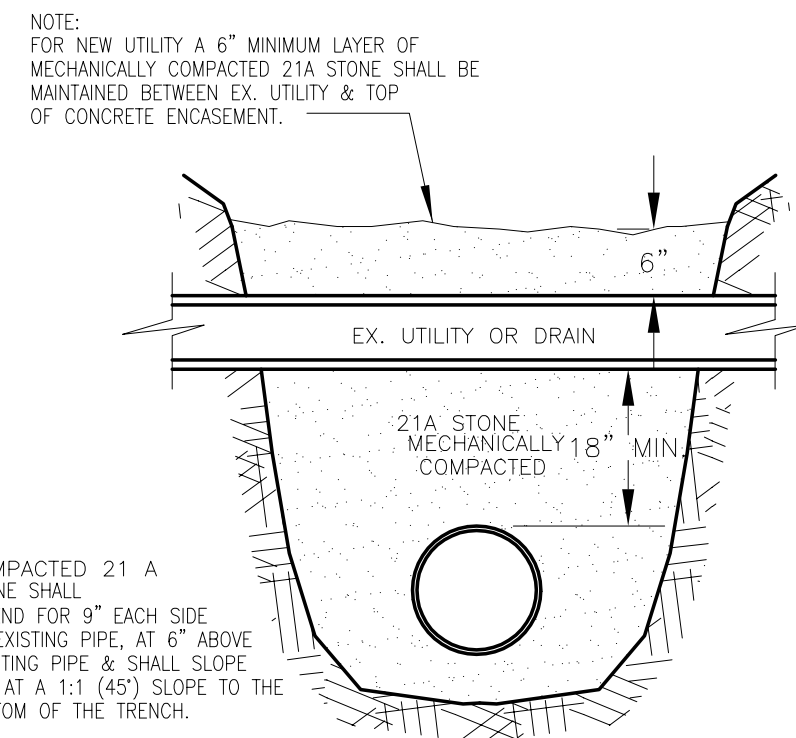

STANDARD PIPE SUPPORT

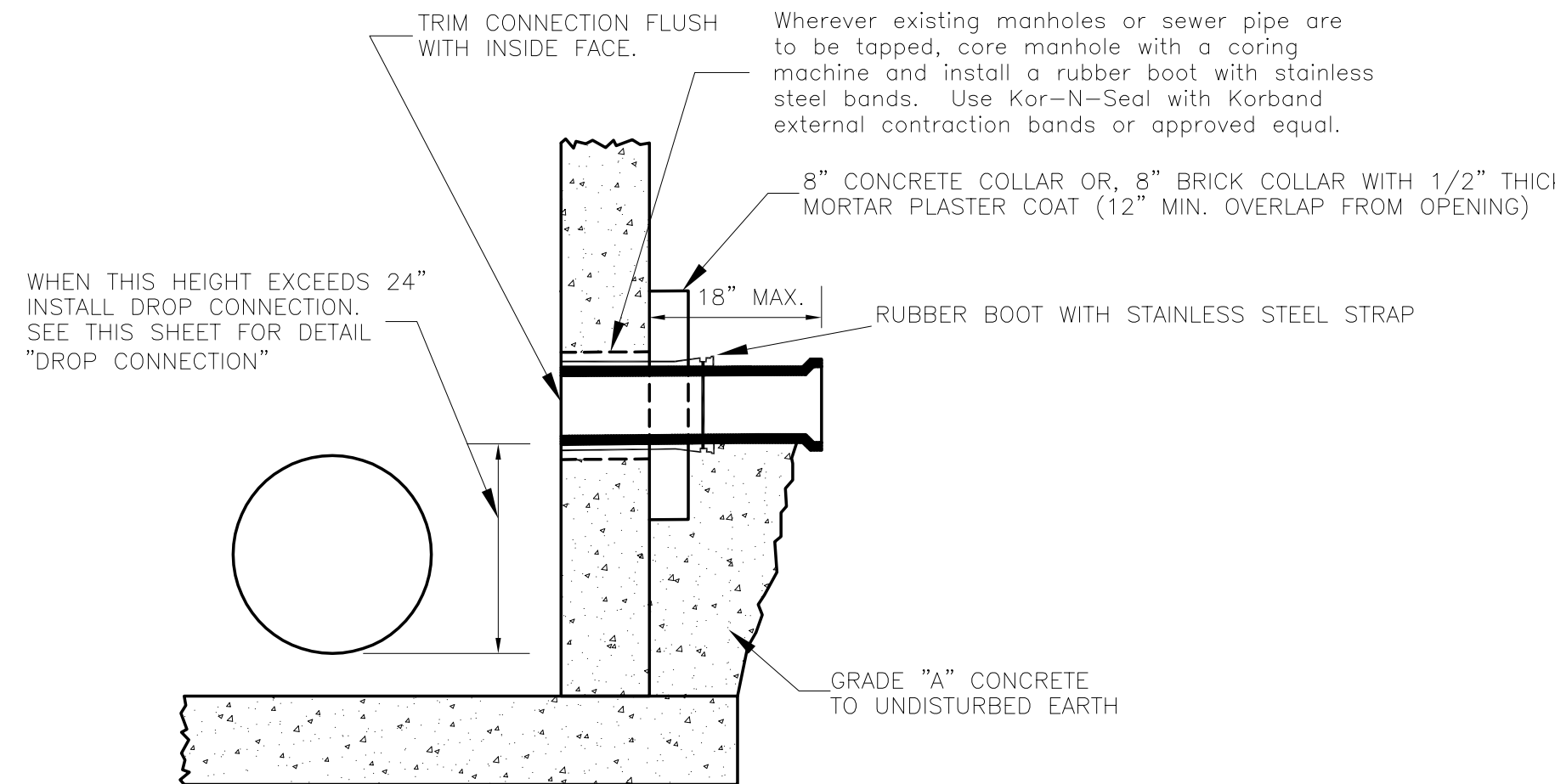

STANDARD CONNECTION TO EXISTING MANHOLE

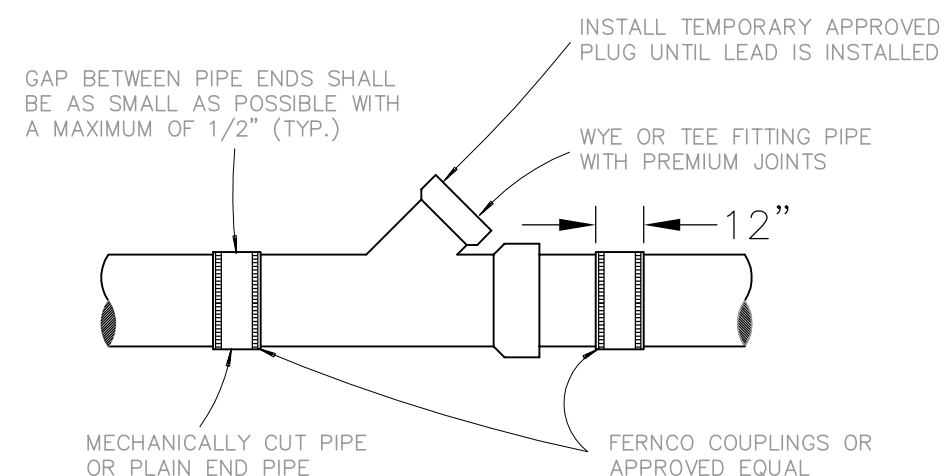

METHOD A

WYE PIPE INSERTION WITH FLEXIBLE COUPLINGS
 (TO BE USED FOR PIPES UP TO 18" MAX. DIAMETER)

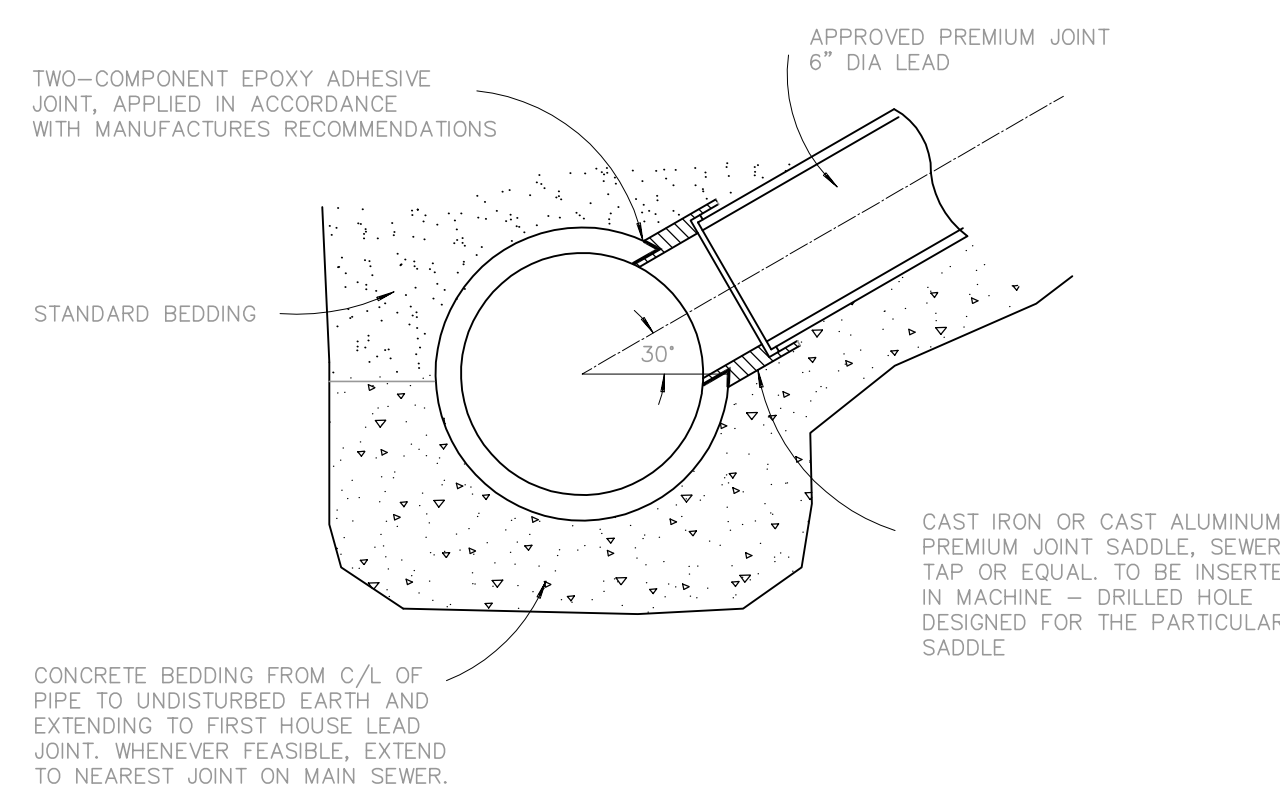

METHOD B

SADDLE TAP - ALL SIZE OF PVC SEWER

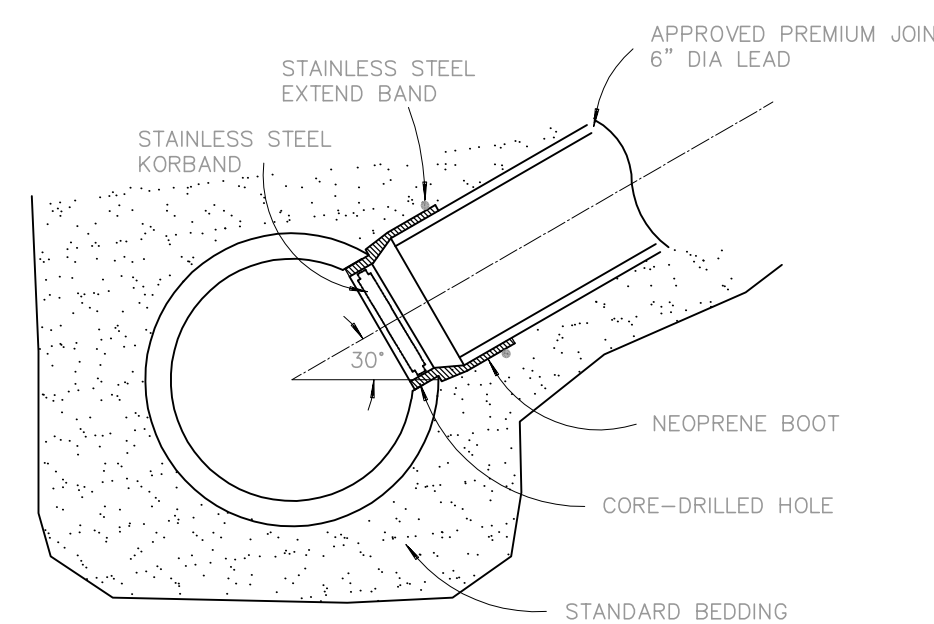

METHOD C

KOR-N-TEE TAP OR APPROVED EQUAL FOR CONCRETE PIPE
 NOTE: METHOD USED TO INSTALL LEAD IN EXISTING SEWER, SHALL BE DETERMINED BY THE CITY OF WOODHAVEN.

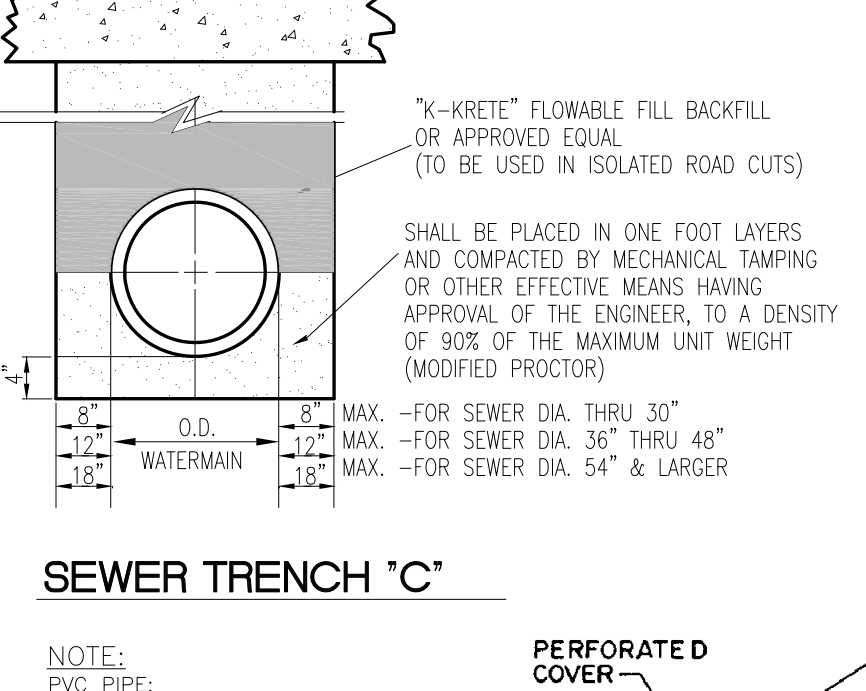
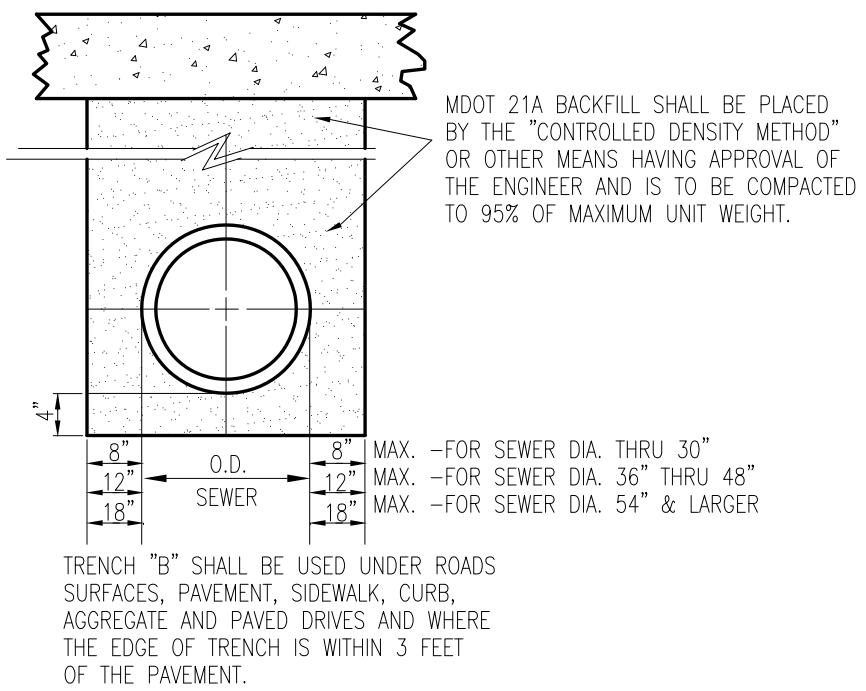
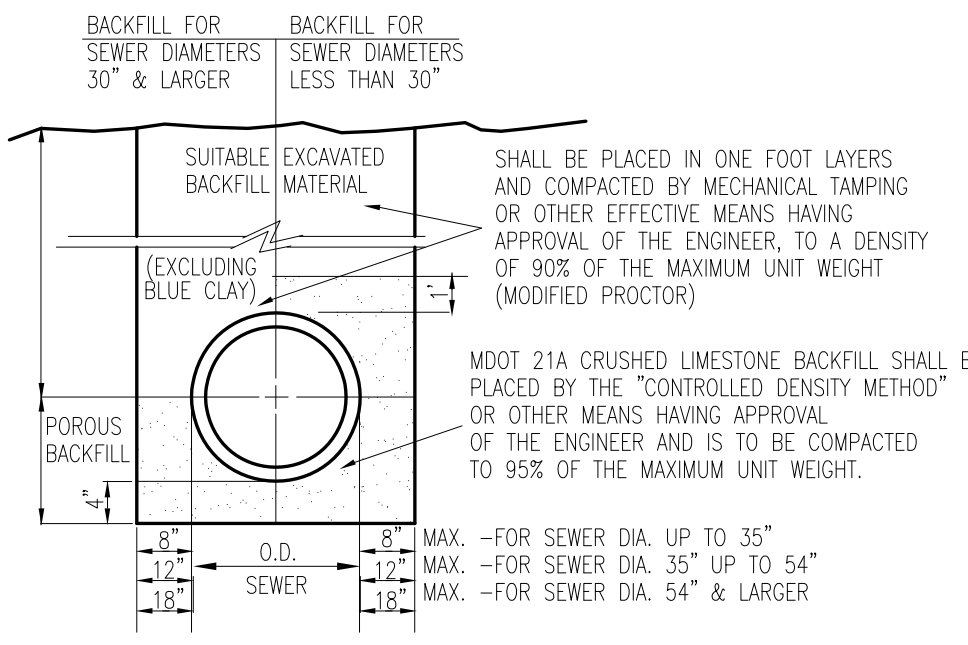

SEWER TRENCH 'A'

NOTE:
PVC PIPE:
MIN. TRENCH WIDTH = 1.5 X O.D. + 12"
(FOR ALL INSTALLATION DEPTHS)

HOPE PIPE: (SEE NOTE 7)
MIN. TRENCH WIDTH = O.D. + 36"
(FOR INSTALLATION DEPTHS UP TO 10')
MIN. TRENCH WIDTH = 3X O.D.
(FOR INSTALLATION DEPTHS BELOW 10')
(O.D. = OUTSIDE DIAMETER OF PIPE)

MAX WIDTH OF TRENCH 12" ABOVE TOP OF PIPE
6" THRU 12" PIPE 30" WIDE
15" THRU 36" PIPE O.D. + 16"
42" THRU 60" PIPE O.D. + 24"
MIN WIDTH OF TRENCH 12" ABOVE TOP OF PIPE SHALL BE 6" ON EACH SIDE OF PIPE

SEWER TRENCH 'B'

NOTE:
PVC PIPE:
MIN. TRENCH WIDTH = 1.5 X O.D. + 12"
(FOR ALL INSTALLATION DEPTHS)

HOPE PIPE: (SEE NOTE 7)
MIN. TRENCH WIDTH = O.D. + 36"
(FOR INSTALLATION DEPTHS UP TO 10')
MIN. TRENCH WIDTH = 3X O.D.
(FOR INSTALLATION DEPTHS BELOW 10')
(O.D. = OUTSIDE DIAMETER OF PIPE)

SEWER TRENCH 'C'

NOTE:
PVC PIPE:
MIN. TRENCH WIDTH = 1.5 X O.D. + 12"
(FOR ALL INSTALLATION DEPTHS)

HOPE PIPE: (SEE NOTE 7)
MIN. TRENCH WIDTH = O.D. + 36"
(FOR INSTALLATION DEPTHS UP TO 10')
MIN. TRENCH WIDTH = 3X O.D.
(FOR INSTALLATION DEPTHS BELOW 10')
(O.D. = OUTSIDE DIAMETER OF PIPE)

M.H. STEPS SHALL BE SPACED AS FOLLOWS:
CONC. BLK. M.H. 18" CENTERS
BRICK M.H. 18" CENTERS
PRECAST M.H. 18" CENTERS

TOP STEP TO BE 2" BELOW TOP OF FRAME

MIN. CONE HEIGHTS AS FOLLOWS:

BRICK	CONCENTRIC	3' 0"
BLOCK	CONCENTRIC	3' 0"
PRECAST	ECCENTRIC	2' 8" OR 3' 4"

CONC. BLOCK MANHOLE:
APPROVED CONC. BLOCK
USE 6" OR 8" THICK BLOCK TO 16" DEPTH
USE 12" THICK BLOCK TO 24" DEPTH
16" BLOCK WALL BELOW 24" DEPTH

BRICK MANHOLE:
APPROVED BRICK
8" BRICK WALL TO 16" DEPTH
12" BRICK WALL TO 24" DEPTH
16" BRICK WALL BELOW 24" DEPTH

PRECAST MANHOLE:
C-478-72 UP TO 32" DEEP
WITH 5" THICK WALL

- SEWER NOTES:**
- ALL CASTING RIMS SHALL BE SET TO GRADE AS FURNISHED BY THE ENGINEER.
 - ALL STORM SEWER PIPE SHALL BE C76-77-III CONCRETE UNLESS OTHERWISE NOTED.
 - ALL CATCH BASIN LEADS SHALL BE 12" DIA. C76-77-III CONCRETE UNLESS OTHERWISE NOTED.
 - CATCH BASIN & INLET FRAME AND COVERS SHALL BE SPECIFIED AS FOLLOWS:
 - WHEN LOCATED IN PAVEMENT EDGE GUTTER LINE, FRAME AND COVER SHALL BE E.J.I.W. No. 5080 OR EQUIV.
 - WHEN LOCATED IN PAVED AREAS OTHER THAN EDGE GUTTER LINE, FRAME SHALL BE E.J.I.W. No. 1010 WITH TYPE "M" COVER OR EQUIV.
 - WHEN LOCATED IN YARD AREAS, FRAMES SHALL BE E.J.I.W. No. 1000 WITH TYPE "N" OR "M" COVER OR EQUIV.
 - MANHOLE STEPS:
 - A METAL RECORDING DETECTOR TAPE SUCH AS MANUFACTURED BY GRIFFOLYN UNDER THE BRAND NAME TERRATAPE, P.O. BOX 33248, HOUSTON, TEXAS 77033 SHALL BE INSTALLED OVER THE STORM SEWER.

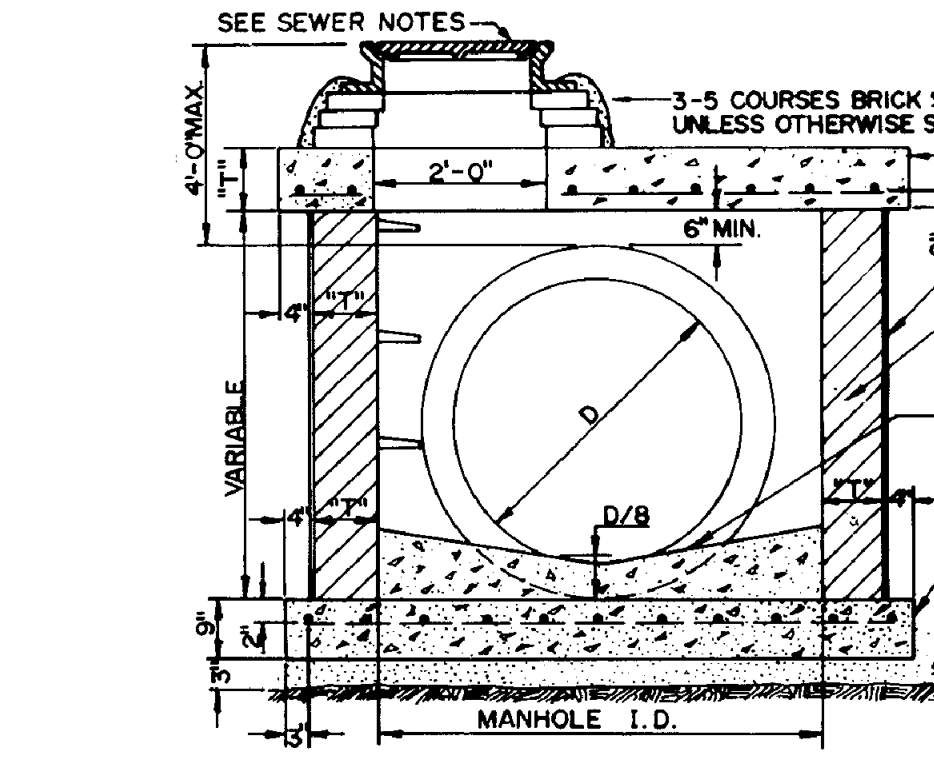
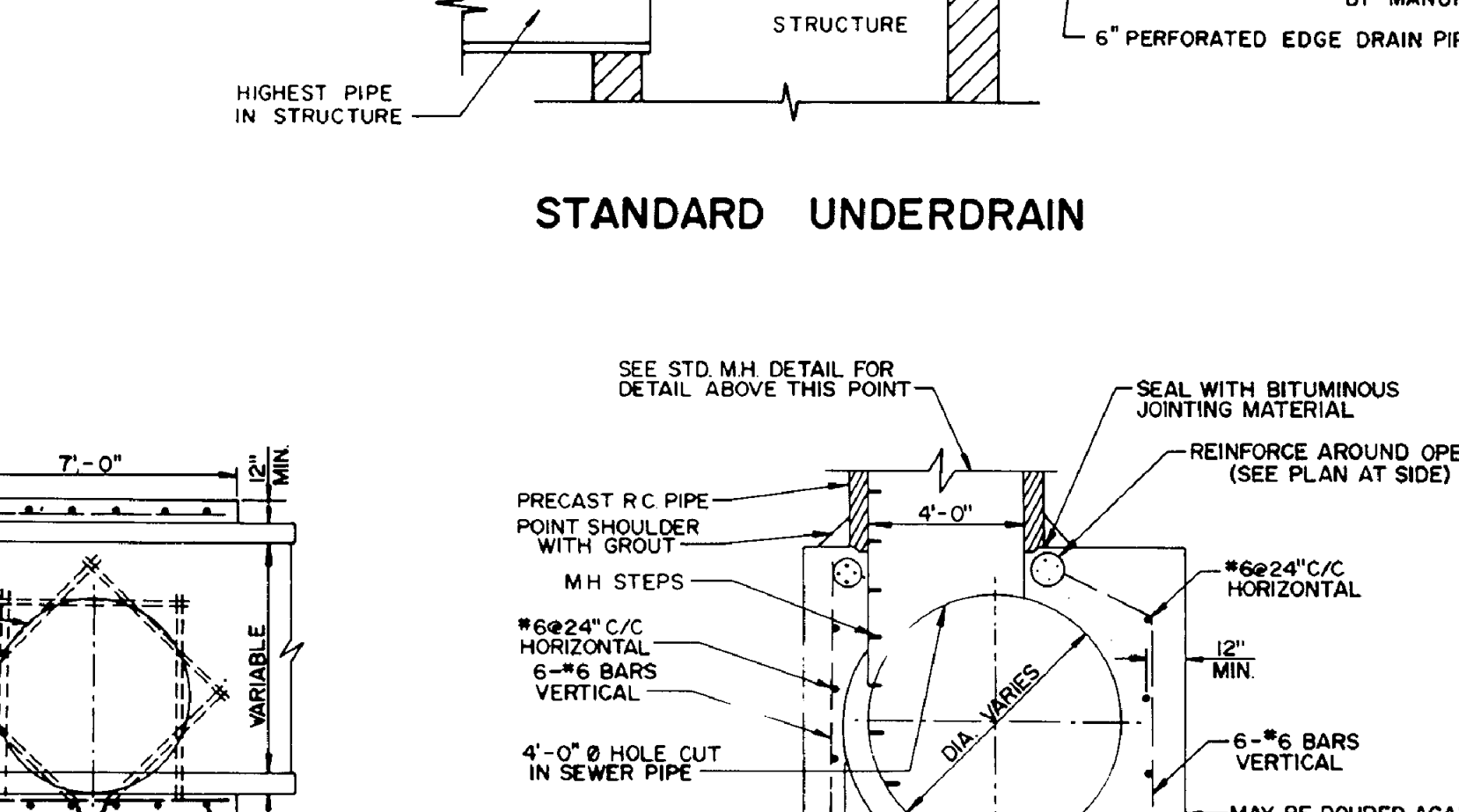
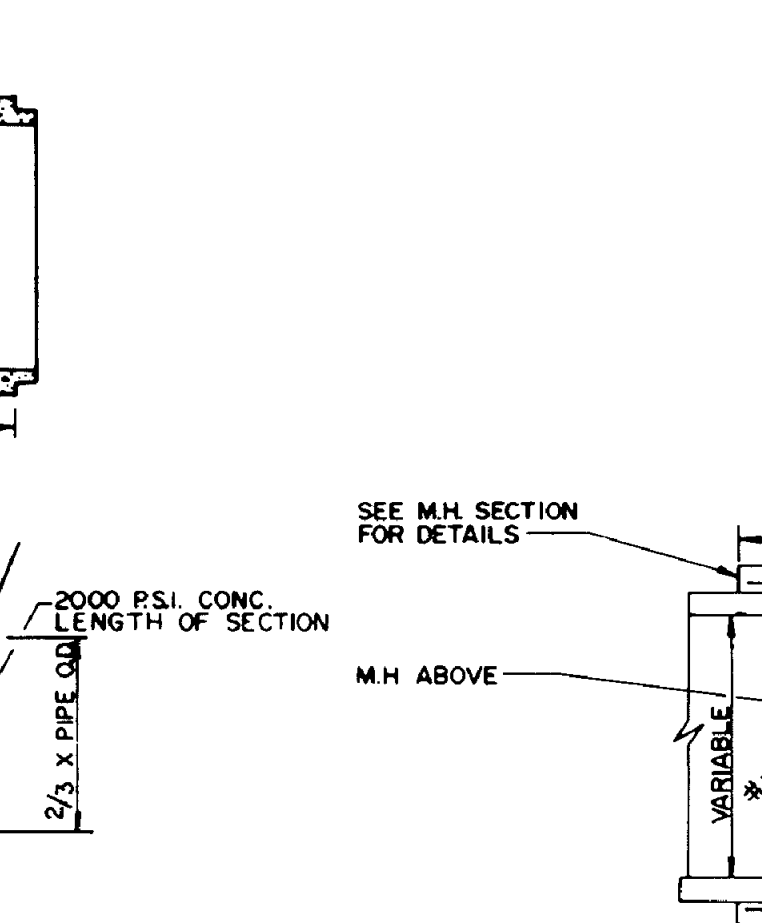
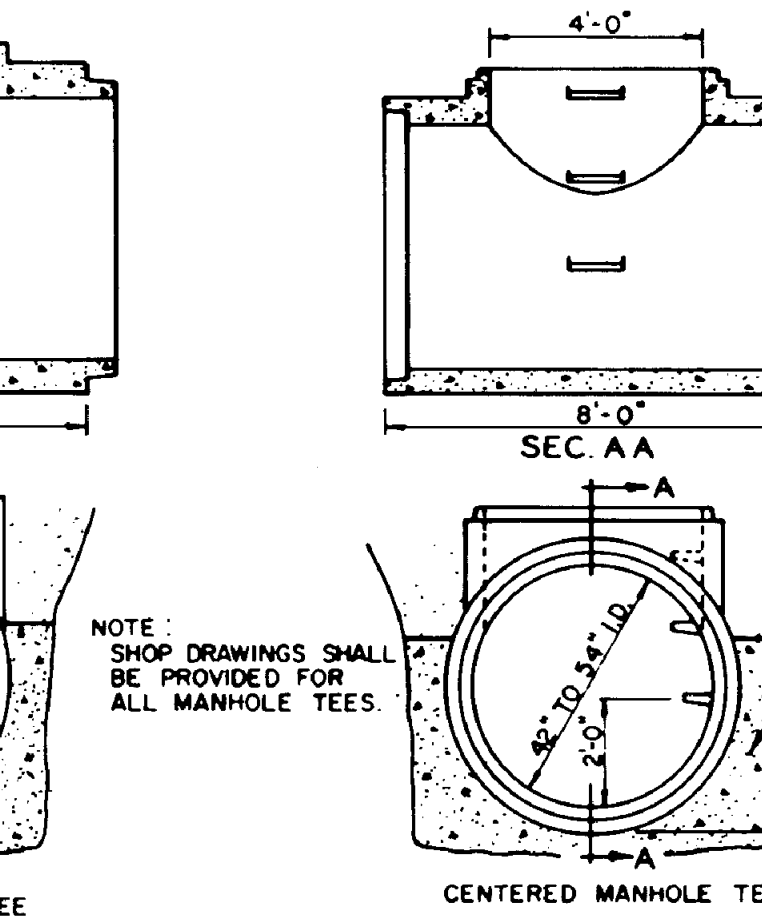
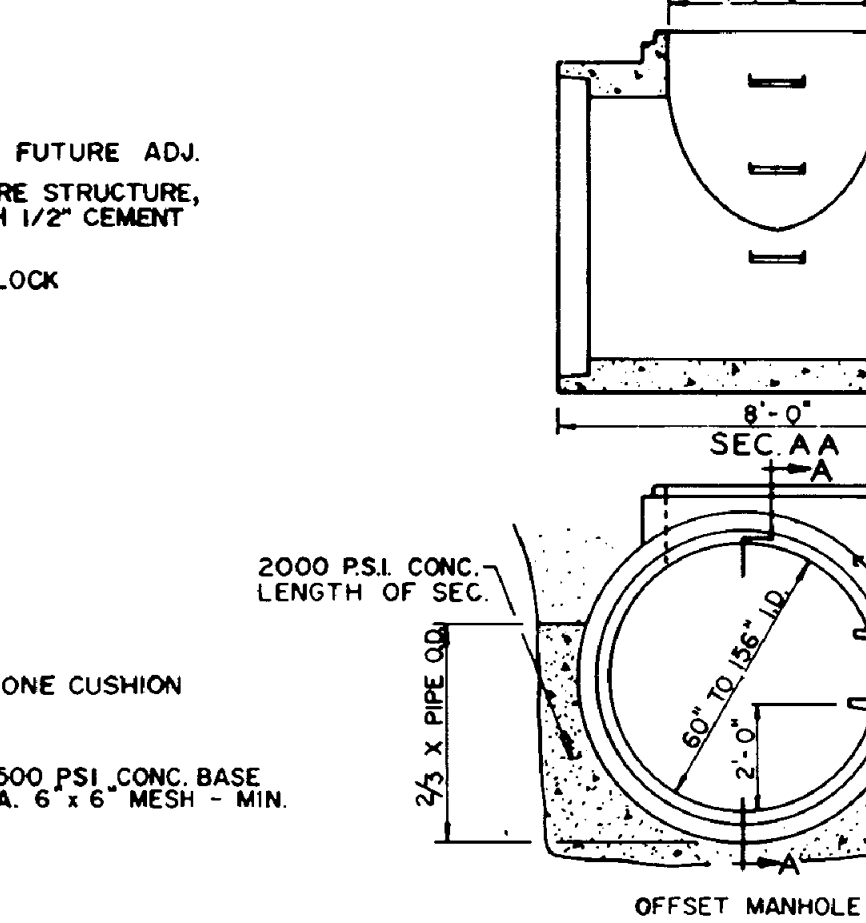
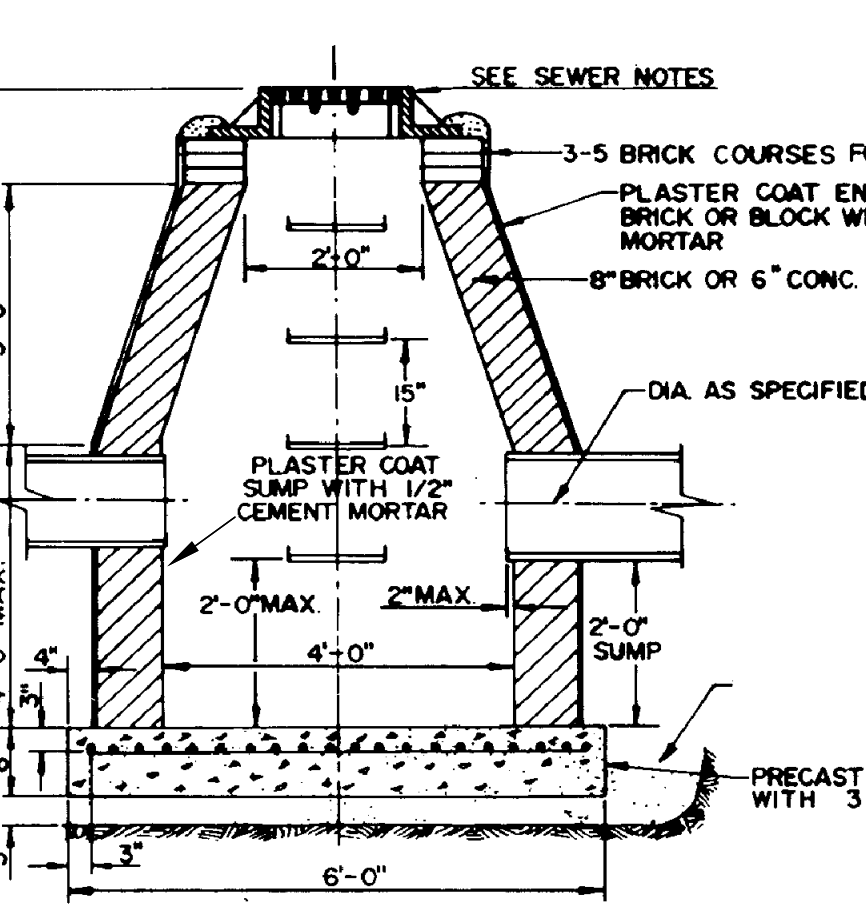
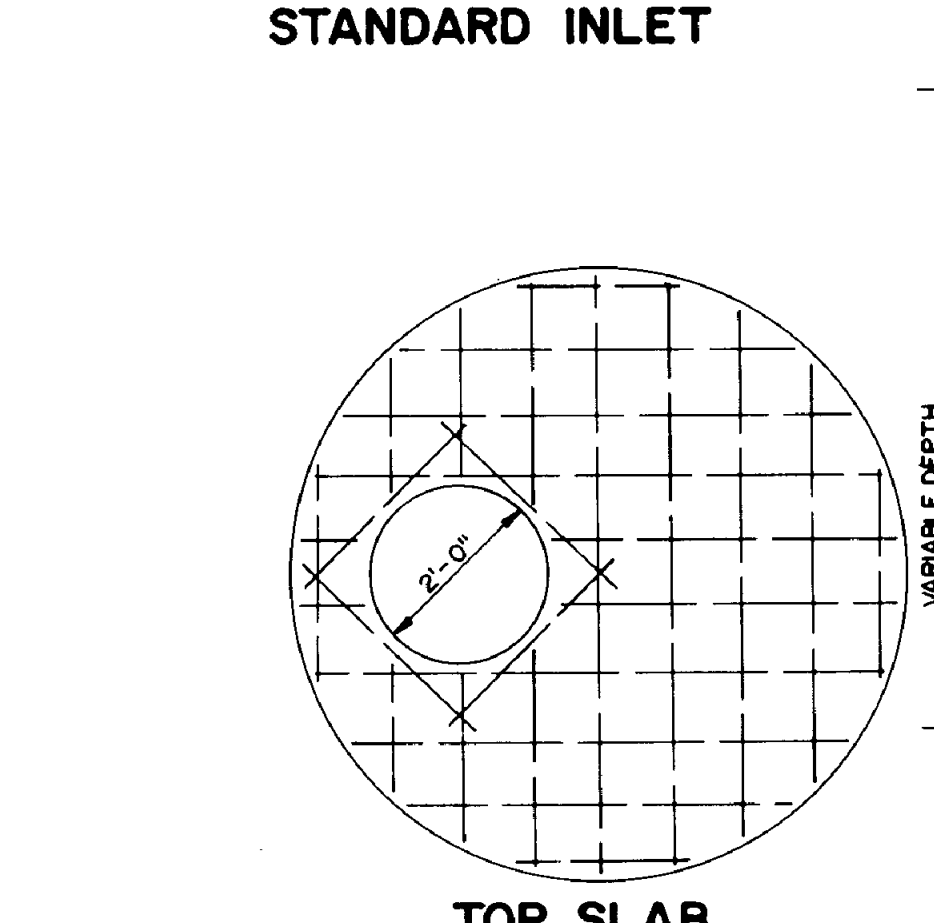
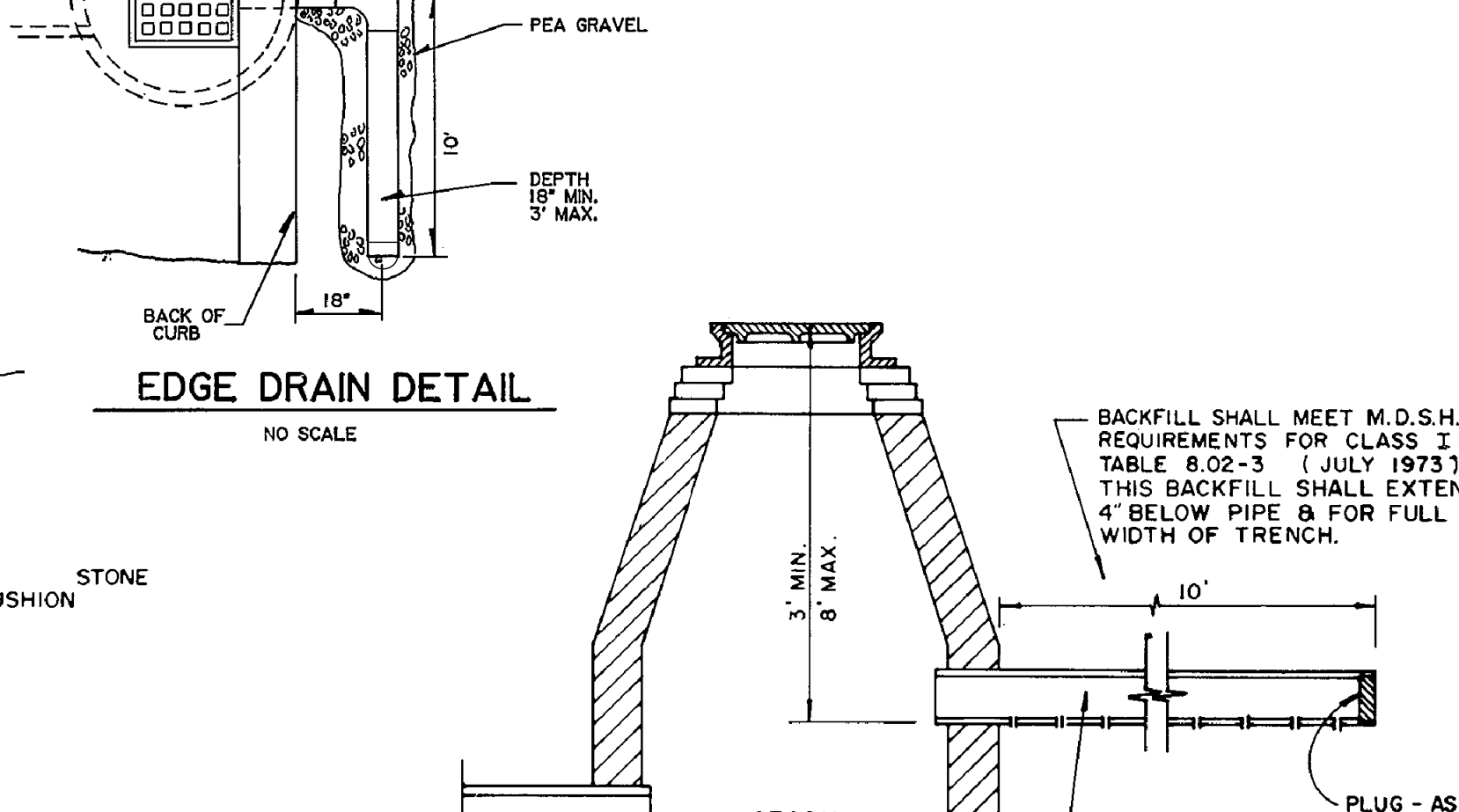
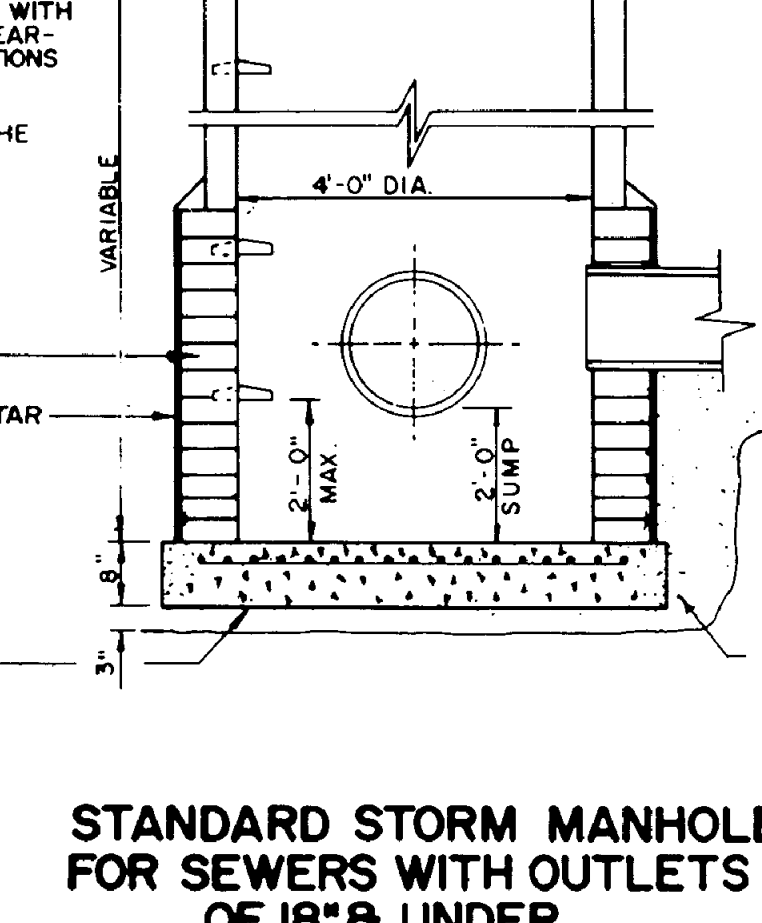
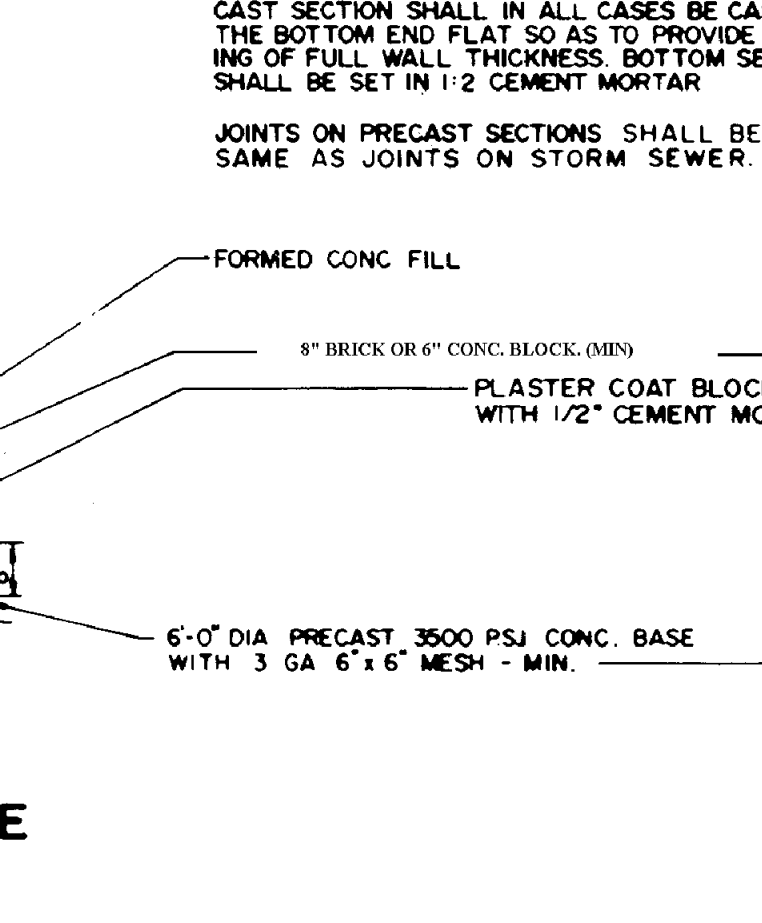
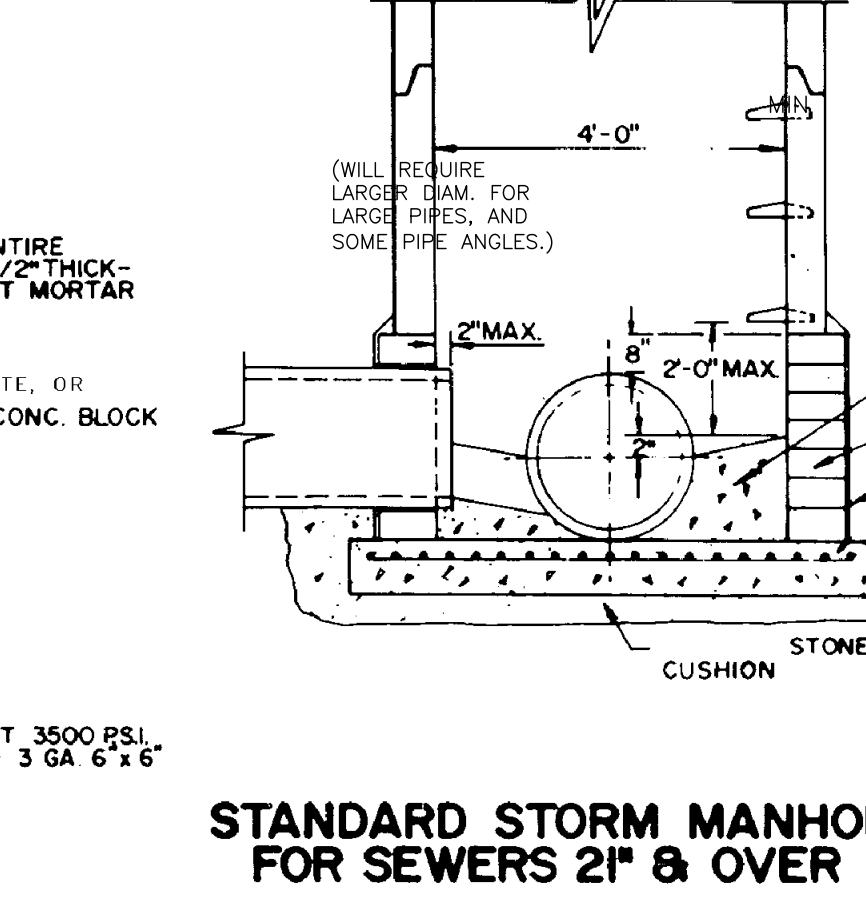
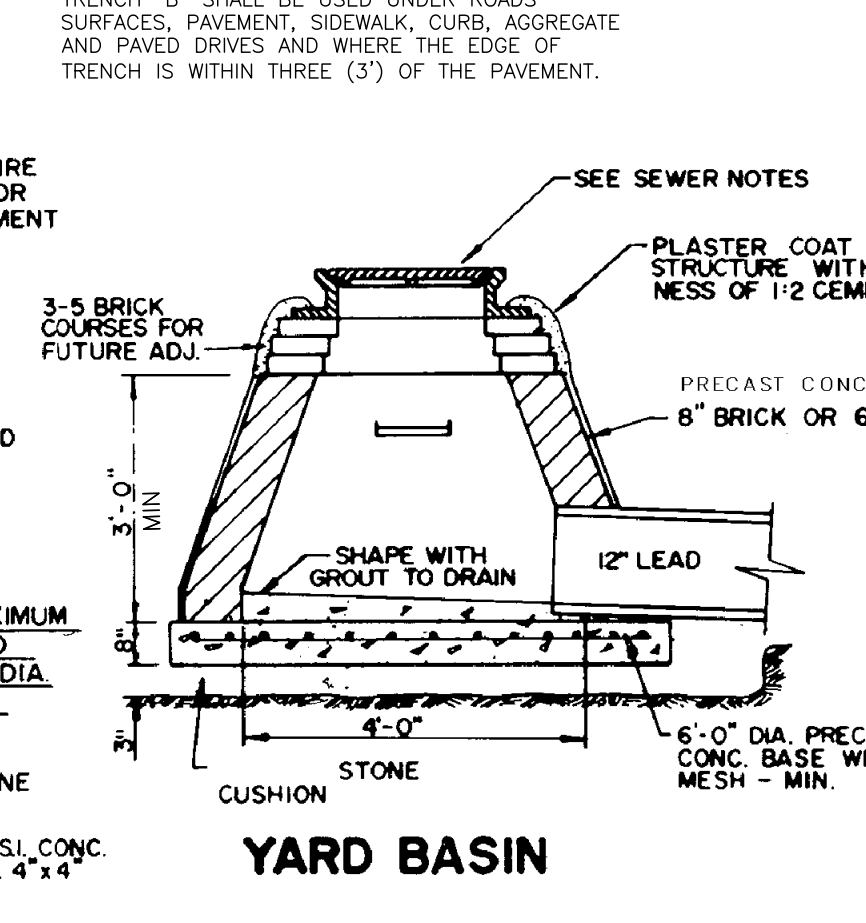
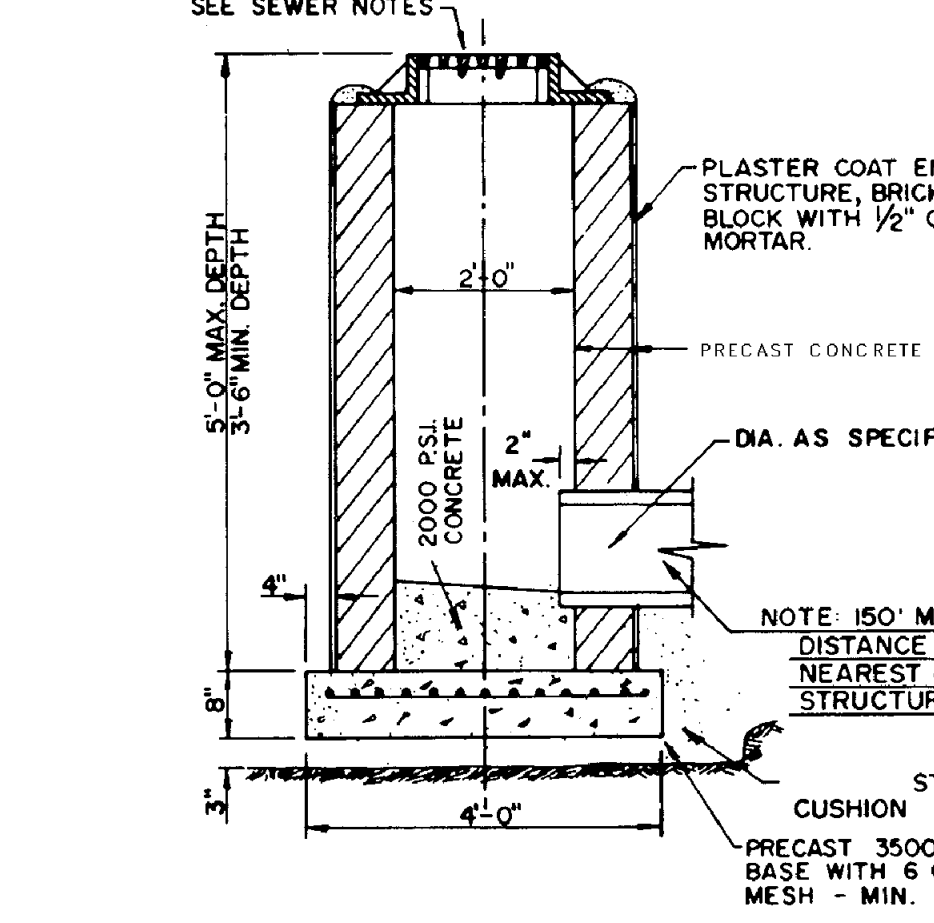

OUTLET I.D.	M.H. I.D.	TOP SLAB I.D.	WALLS	REINF.
24" OR LESS	4'-0"	9"	8"	#6 @ 6" E/WAY
30"	4'-0"	9"	8"	#6 @ 6" E/WAY
36"	4'-0"	9"	12"	#6 @ 6" E/WAY
42"	5'-0"	10"	12"	#6 @ 6" E/WAY
48"	6'-0"	11"	12"	#6 @ 6" E/WAY

* TOP SLAB
** 2' SUMP REQ. FOR MANHOLE WITH OUTLETS OF 18" AND UNDER.

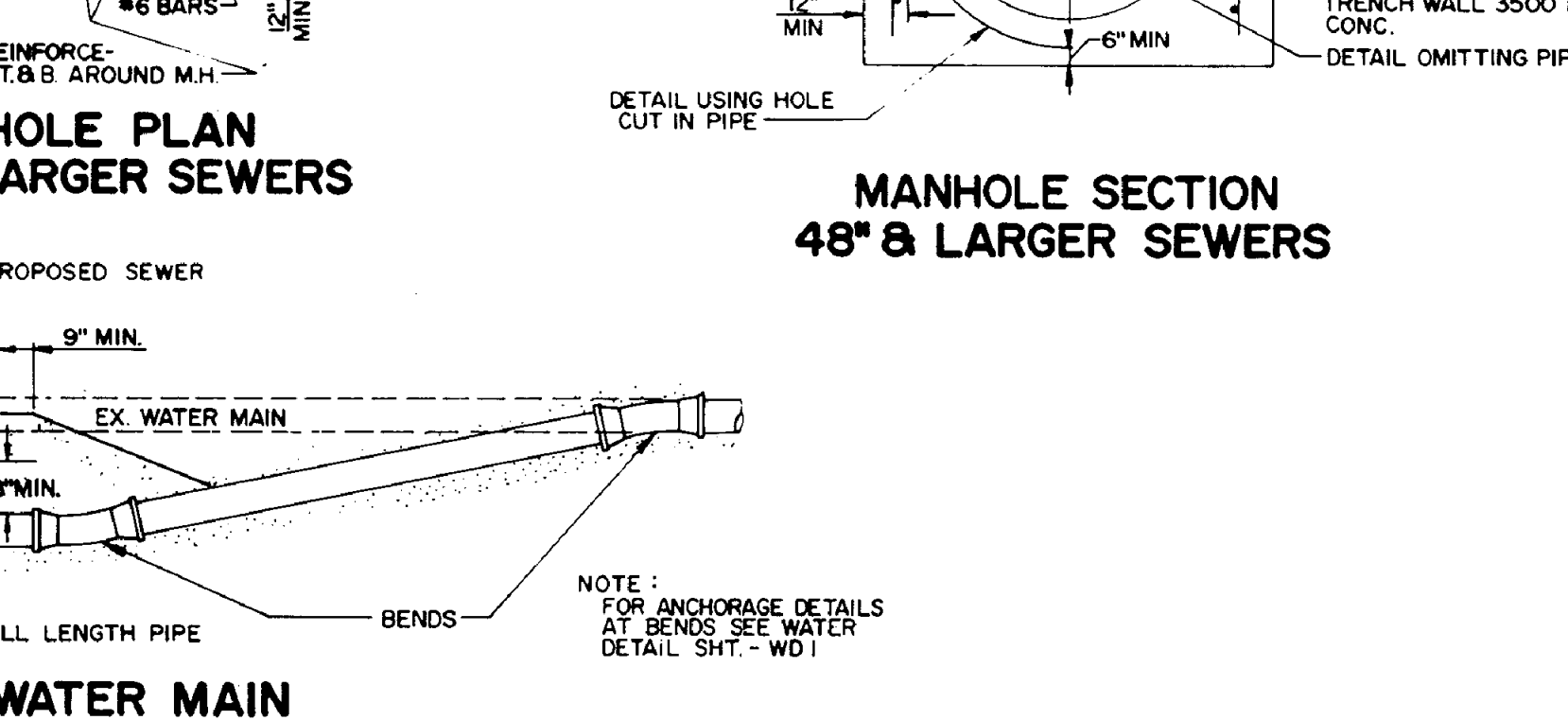
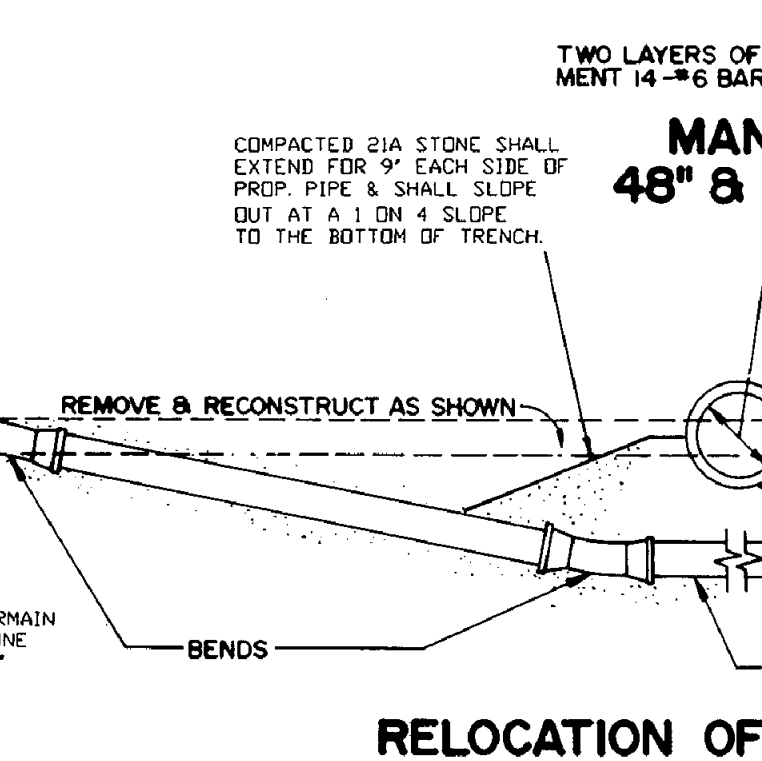
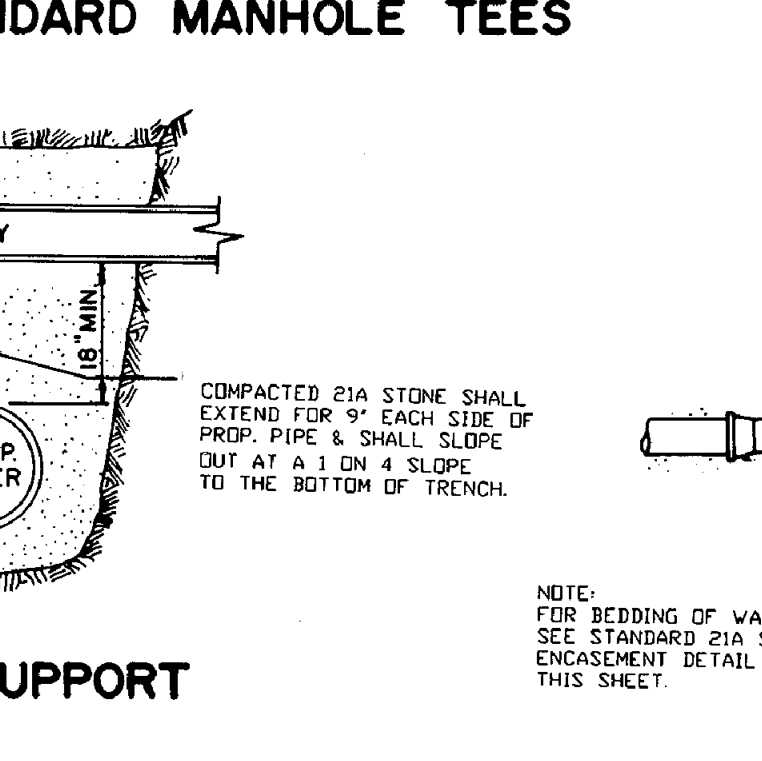
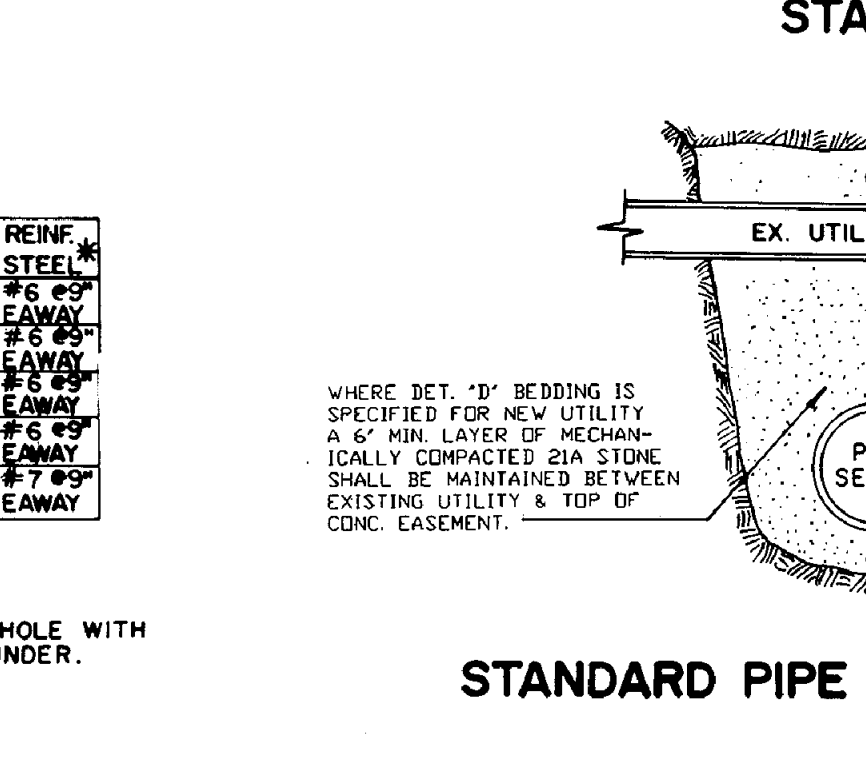

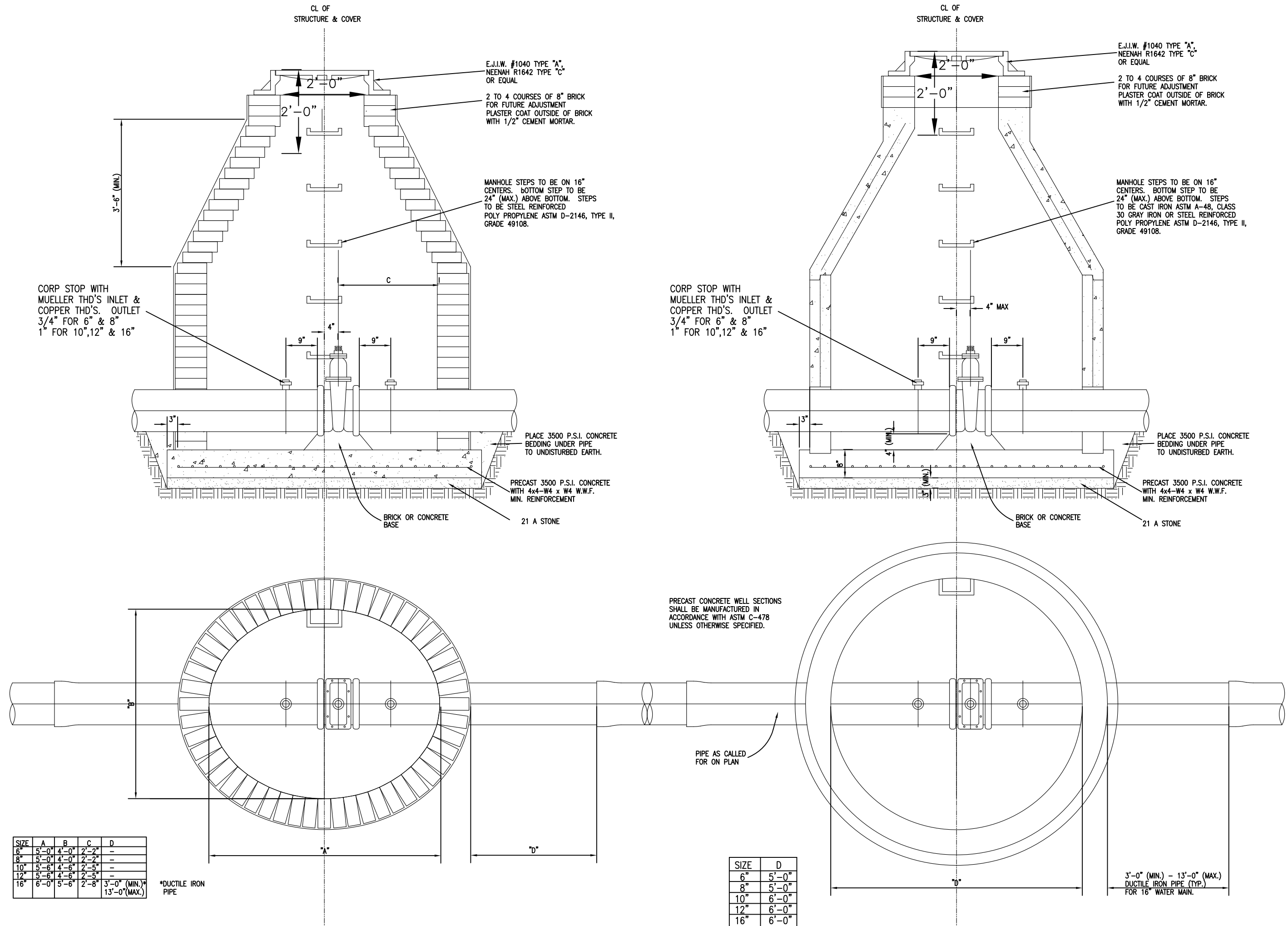

SIZE	A	B	C	D
6"	1'-0"	1'-0"	1'-0"	1'-0"
8"	1'-0"	1'-0"	1'-0"	1'-0"
10"	1'-0"	1'-0"	1'-0"	1'-0"
12"	1'-0"	1'-0"	1'-0"	1'-0"
16"	1'-0"	1'-0"	1'-0"	1'-0"

SIZE	D
6"	5'-0"
8"	5'-0"
10"	6'-0"
12"	6'-0"
16"	6'-0"

6' TO 16' BLOCK GATE VALVE AND WELL

(TO BE USED IN SPECIAL CIRCUMSTANCES APPROVED BY THE CITY)

- NOTE:
1. INSTALL ADDITIONAL FITTINGS & SPIGOT PIPE AS NECESSARY BETWEEN WATERMAIN & VALVE BOX TO ADJUST FOR PROPER LOCATION AND GRADE OF HYDRANT.
 2. VERTICAL ANCHORAGES WILL BE REQUIRED ON ALL VERTICAL HYDRANT BENDS IN EXCESS OF 11 1/4'.
 3. WHERE HYDRANTS ARE INSTALLED ON EXISTING MAINS THAT ARE TO BE PLACED BACK INTO SERVICE IMMEDIATELY, PLACE CONC. BRICK OR BLOCK TO UNDISTURBED EARTH AND ENCASE WITH CONC. OR USE RESTRAINING GLANDS.
 4. ALL FITTINGS TO BE MECHANICAL JOINTS.
 5. MAXIMUM DEPTH OF BURY - 8' 0"

STANDARD 6' TO 16' PRECAST GATE VALVE AND WELL

(BLOCK STRUCTURES TO BE USED ONLY IN SPECIAL CIRCUMSTANCES APPROVED BY THE CITY)

- NOTE:
1. INSTALL ADDITIONAL FITTINGS & SPIGOT PIPE AS NECESSARY BETWEEN WATERMAIN & VALVE BOX TO ADJUST FOR PROPER LOCATION AND GRADE OF HYDRANT.
 2. VERTICAL ANCHORAGES WILL BE REQUIRED ON ALL VERTICAL HYDRANT BENDS IN EXCESS OF 11 1/4'.
 3. WHERE HYDRANTS ARE INSTALLED ON EXISTING MAINS THAT ARE TO BE PLACED BACK INTO SERVICE IMMEDIATELY, PLACE CONC. BRICK OR BLOCK TO UNDISTURBED EARTH AND ENCASE WITH CONC. OR USE RESTRAINING GLANDS.
 4. ALL FITTINGS TO BE MECHANICAL JOINTS.
 5. MAXIMUM DEPTH OF BURY - 8' 0"

STANDARD 8' TO 12' TAPPING SLEEVE, VALVE AND WELL

(BLOCK STRUCTURES TO BE USED ONLY IN SPECIAL CIRCUMSTANCES APPROVED BY THE CITY)

- NOTE:
1. INSTALL ADDITIONAL FITTINGS & SPIGOT PIPE AS NECESSARY BETWEEN WATERMAIN & VALVE BOX TO ADJUST FOR PROPER LOCATION AND GRADE OF HYDRANT.
 2. VERTICAL ANCHORAGES WILL BE REQUIRED ON ALL VERTICAL HYDRANT BENDS IN EXCESS OF 11 1/4'.
 3. WHERE HYDRANTS ARE INSTALLED ON EXISTING MAINS THAT ARE TO BE PLACED BACK INTO SERVICE IMMEDIATELY, PLACE CONC. BRICK OR BLOCK TO UNDISTURBED EARTH AND ENCASE WITH CONC. OR USE RESTRAINING GLANDS.
 4. ALL FITTINGS TO BE MECHANICAL JOINTS.
 5. MAXIMUM DEPTH OF BURY - 8' 0"

STANDARD 6' TO 16' PRECAST TAPPING SLEEVE VALVE AND WELL

(BLOCK STRUCTURES TO BE USED ONLY IN SPECIAL CIRCUMSTANCES APPROVED BY THE CITY)

- NOTE:
1. INSTALL ADDITIONAL FITTINGS & SPIGOT PIPE AS NECESSARY BETWEEN WATERMAIN & VALVE BOX TO ADJUST FOR PROPER LOCATION AND GRADE OF HYDRANT.
 2. VERTICAL ANCHORAGES WILL BE REQUIRED ON ALL VERTICAL HYDRANT BENDS IN EXCESS OF 11 1/4'.
 3. WHERE HYDRANTS ARE INSTALLED ON EXISTING MAINS THAT ARE TO BE PLACED BACK INTO SERVICE IMMEDIATELY, PLACE CONC. BRICK OR BLOCK TO UNDISTURBED EARTH AND ENCASE WITH CONC. OR USE RESTRAINING GLANDS.
 4. ALL FITTINGS TO BE MECHANICAL JOINTS.
 5. MAXIMUM DEPTH OF BURY - 8' 0"

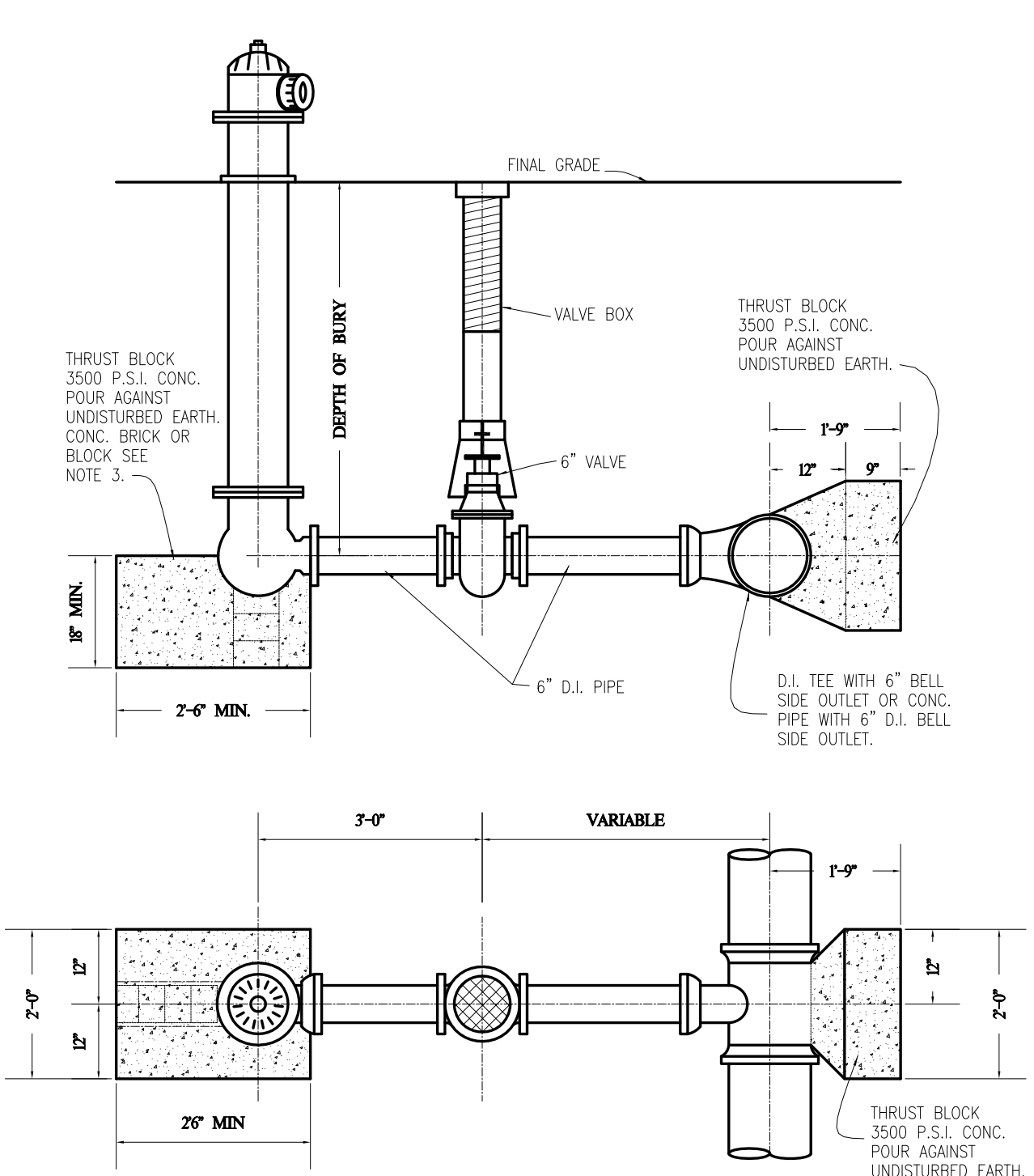

STANDARD HYDRANT SETTING

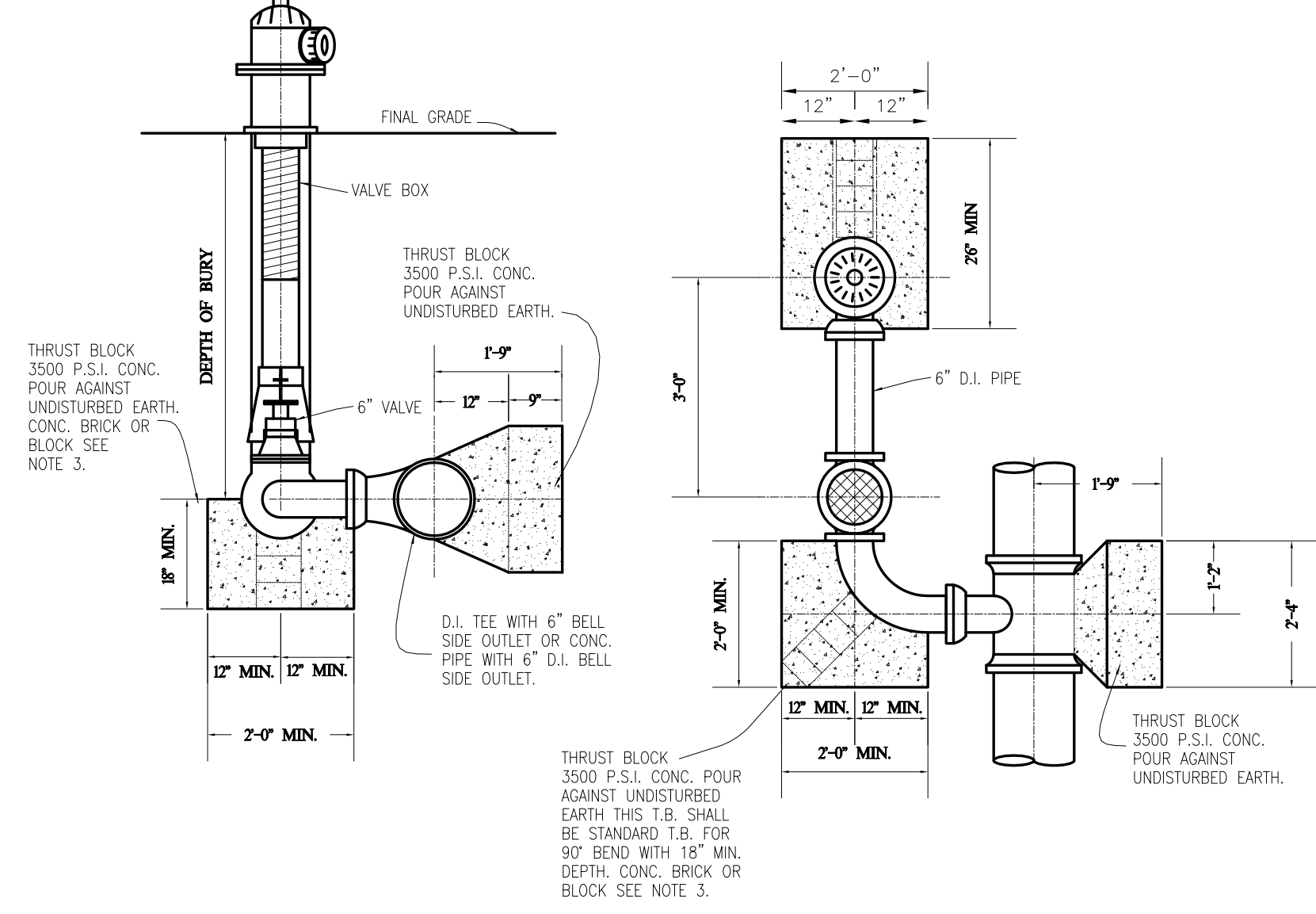

CLOSE COUPLE HYDRANT SETTING

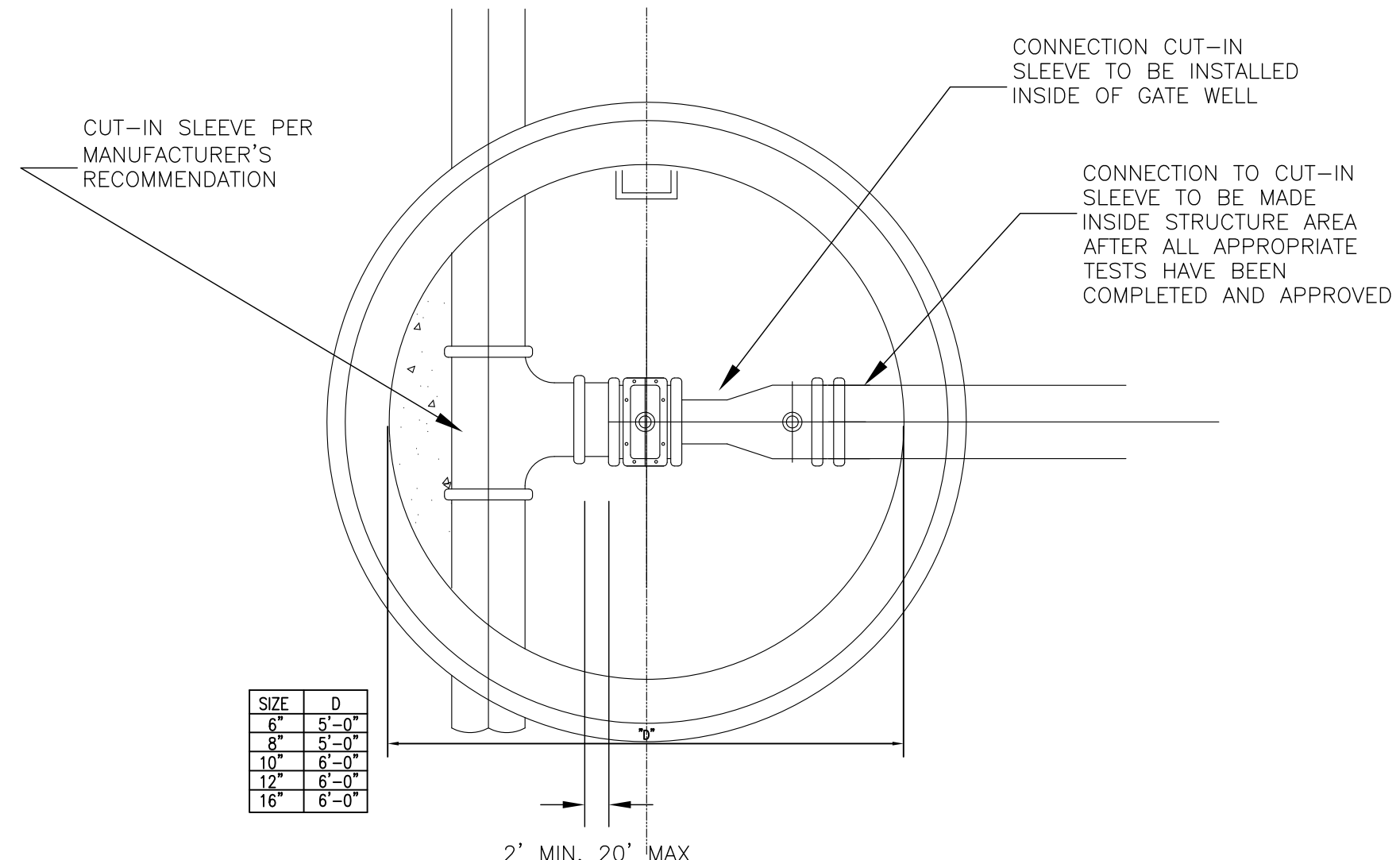

CUT-IN SLEEVE, VALVE, AND WELL

ENGINEERING THE FUTURE

2674 WEST JEFFERSON AVE.
SUITE 201
TROY, MI 48063
(734) 692-3300
FAX (734) 692-3303

HENNESSEY ENGINEERS, INC.

TITLE STANDARD WATER DETAILS

CITY OF ECORSE
WAYNE COUNTY, MICHIGAN

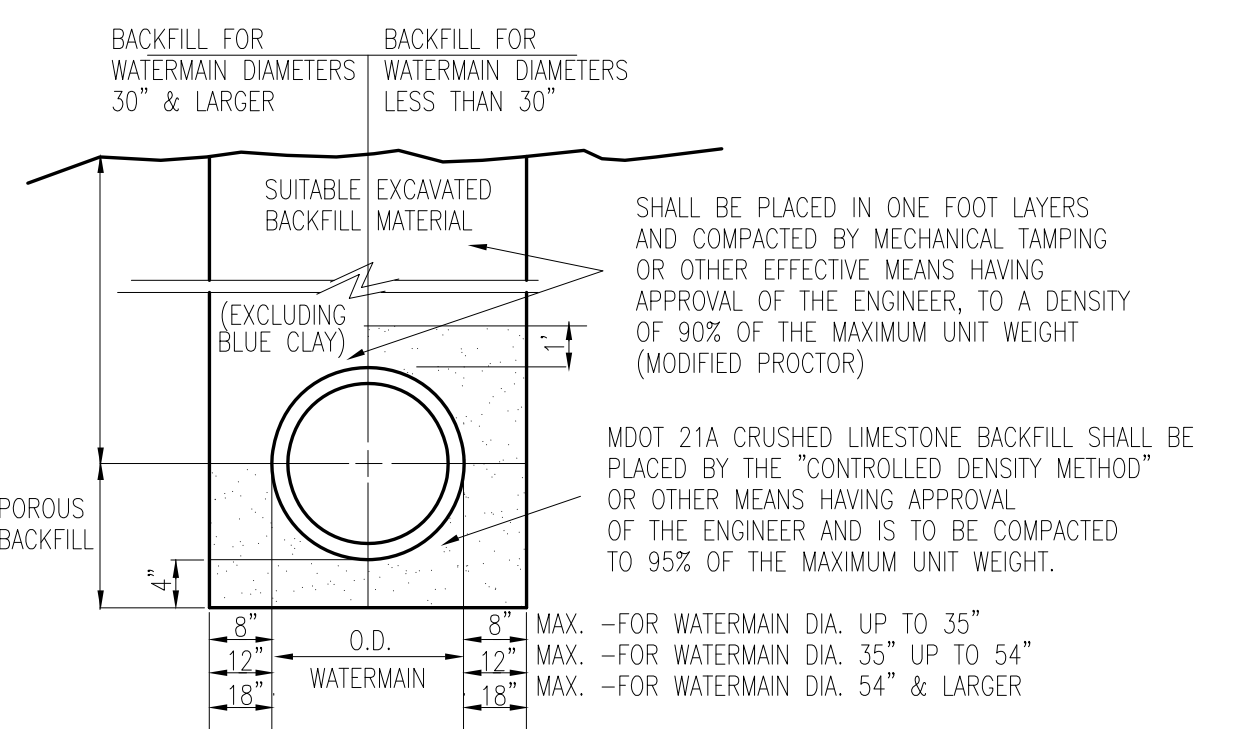

TRENCH "A"

NOTE:
TRENCH A&B DETAIL ARE FOR LOCATIONS OUTSIDE OF WAYNE COUNTY RIGHT-OF-WAY ONLY

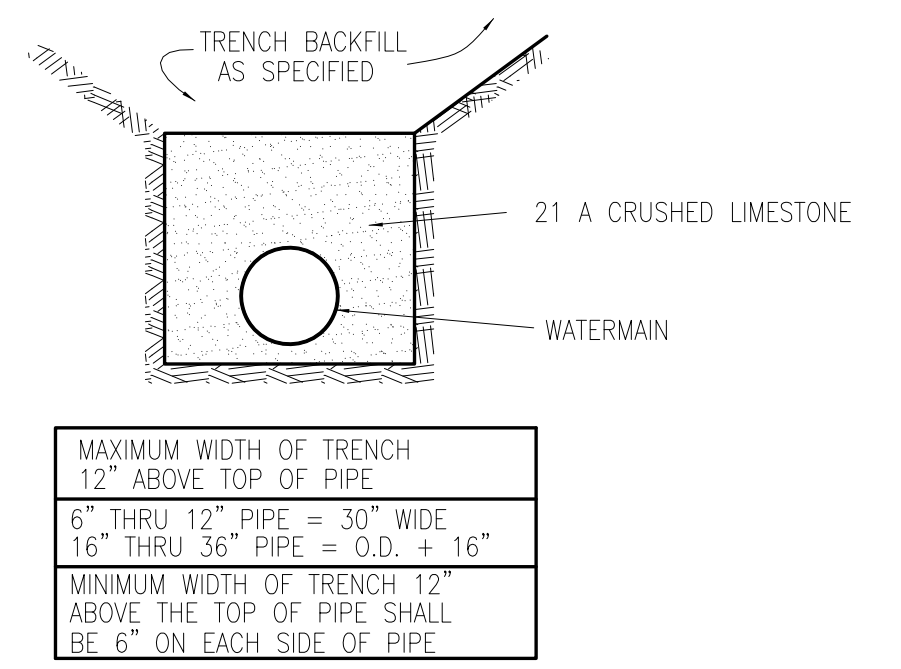

WATERMAIN BEDDING DETAIL

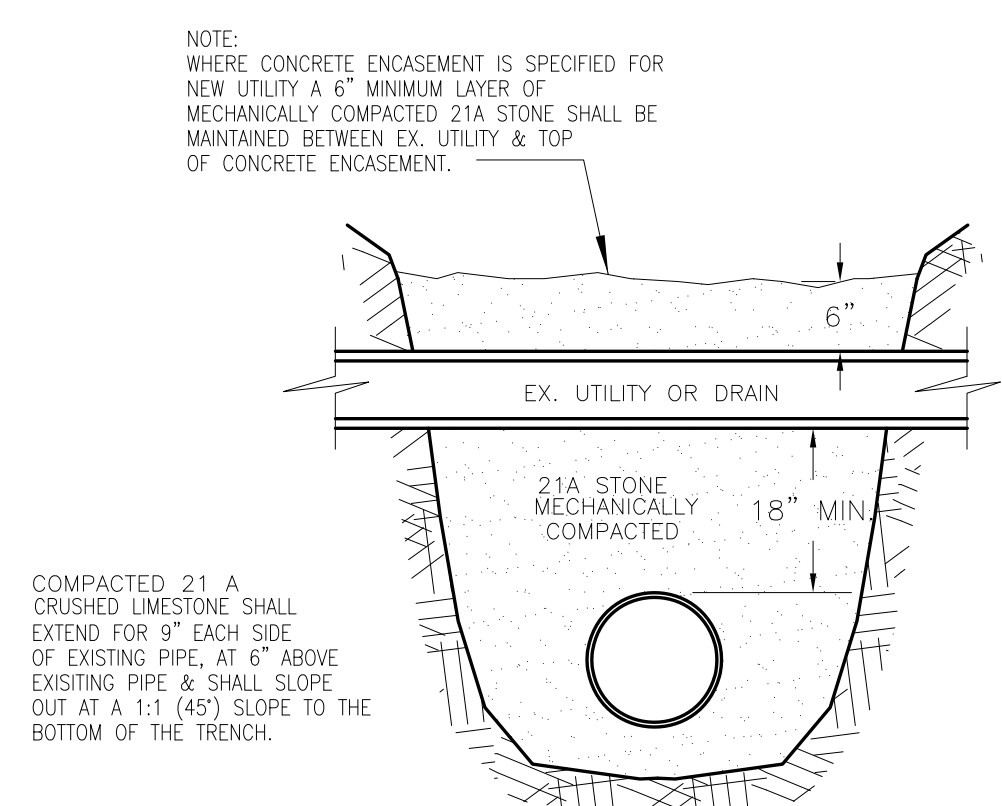

STANDARD PIPE SUPPORT

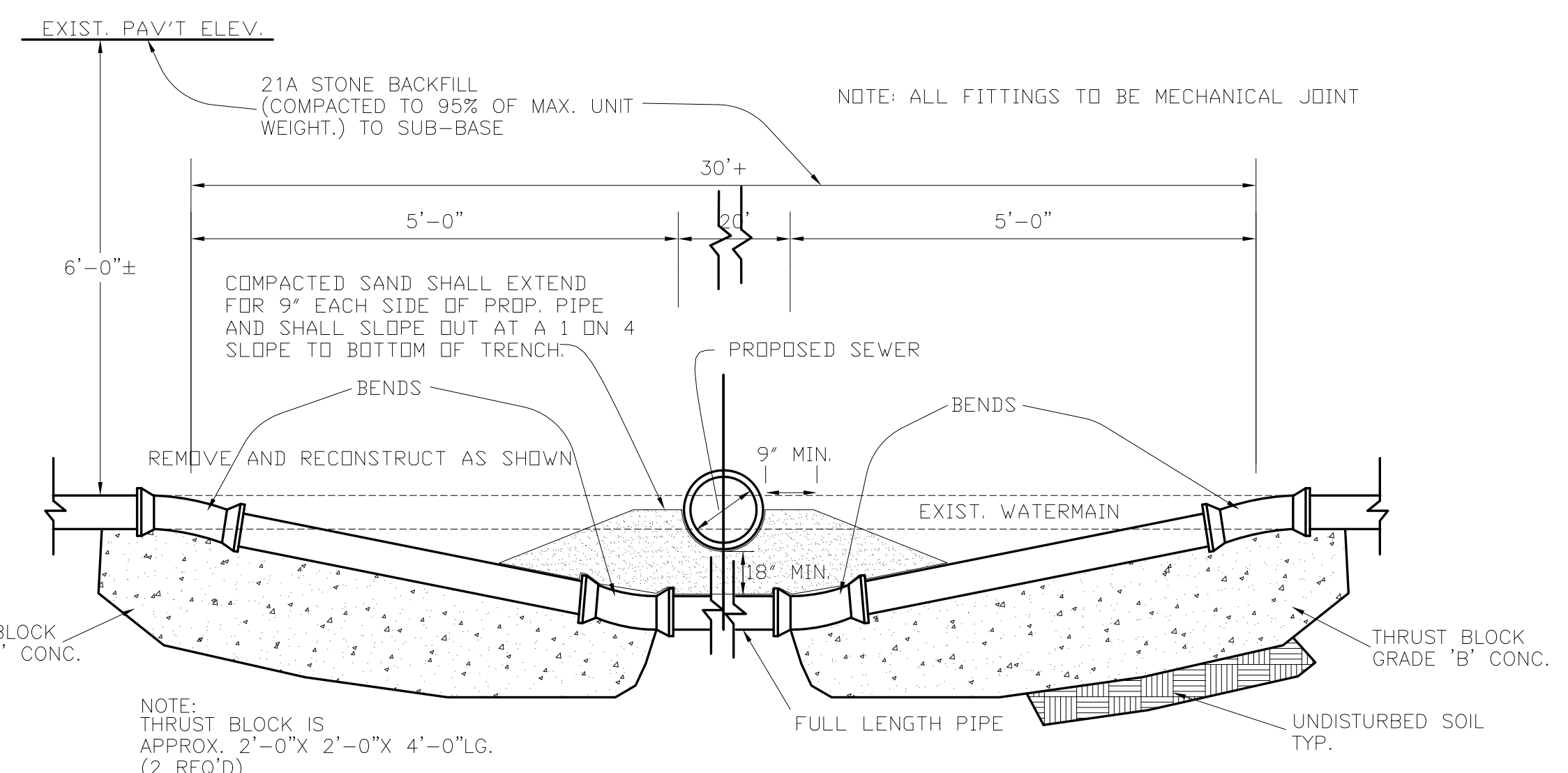

WATERMAIN LOWERING DETAIL

NOTE: ALL WATERMAIN FITTINGS ARE TO BE MECHANICAL JOINTS USING CORE-BLUE BOLTS.

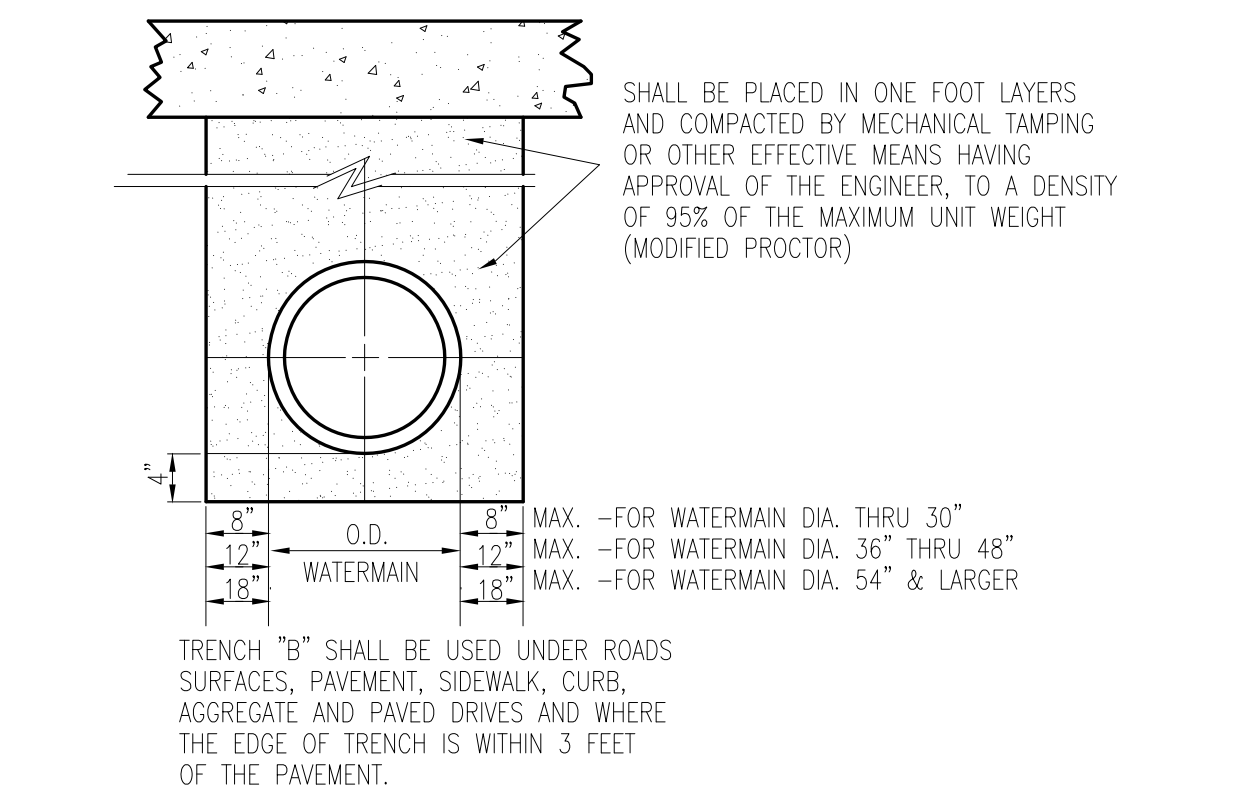

TRENCH "B"

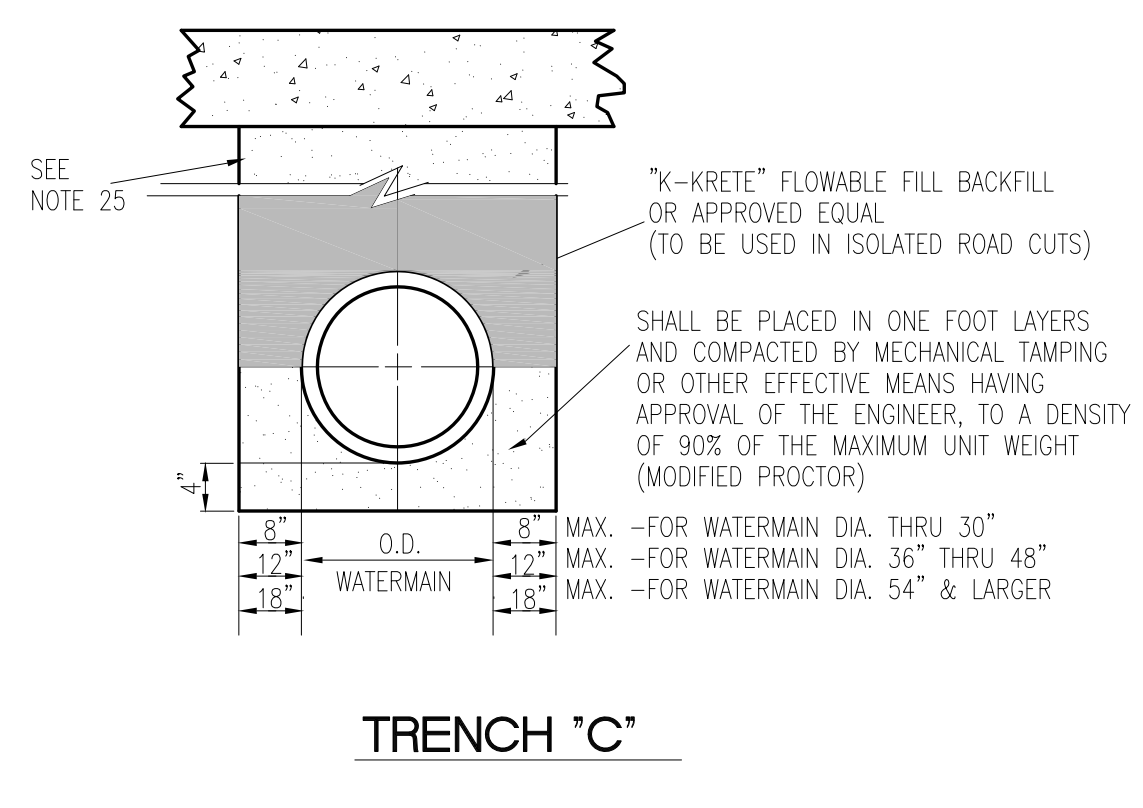

TRENCH "C"

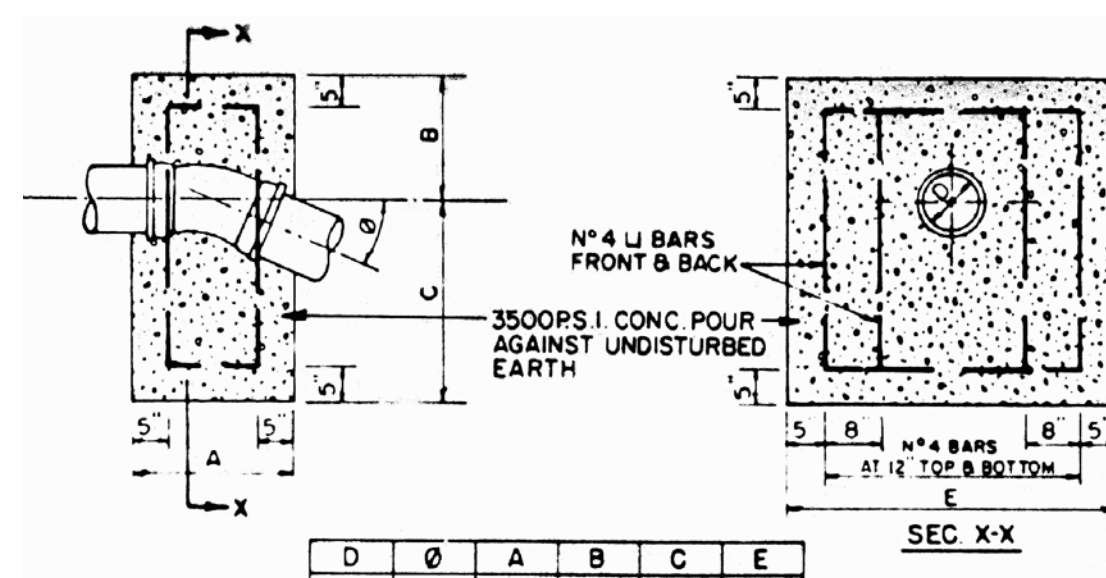

D	Ø	A	B	C	E
6"	22 1/2"	1'-6"	1'-6"	1'-9"	3'-0"
8"	22 1/2"	2'-0"	1'-6"	2'-6"	4'-0"
10"	22 1/2"	2'-0"	2'-6"	3'-0"	4'-0"
12"	22 1/2"	2'-0"	2'-6"	3'-0"	4'-0"
14"	22 1/2"	2'-0"	3'-0"	4'-0"	5'-0"
16"	22 1/2"	2'-2"	3'-0"	4'-6"	5'-0"

* CONTRACTOR SHALL SUBMIT DETAILS OF RESTRAINED JOINTS TO ENGINEER PRIOR TO USE.

ANCHORAGE DETAILS FOR VERTICAL BENDS

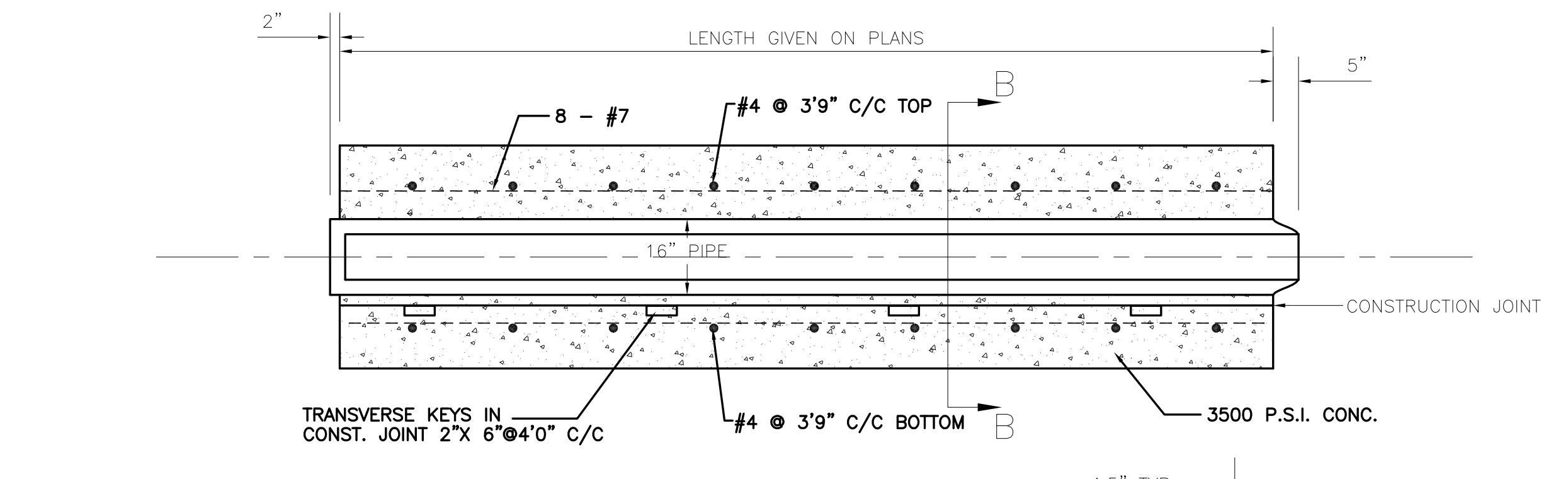
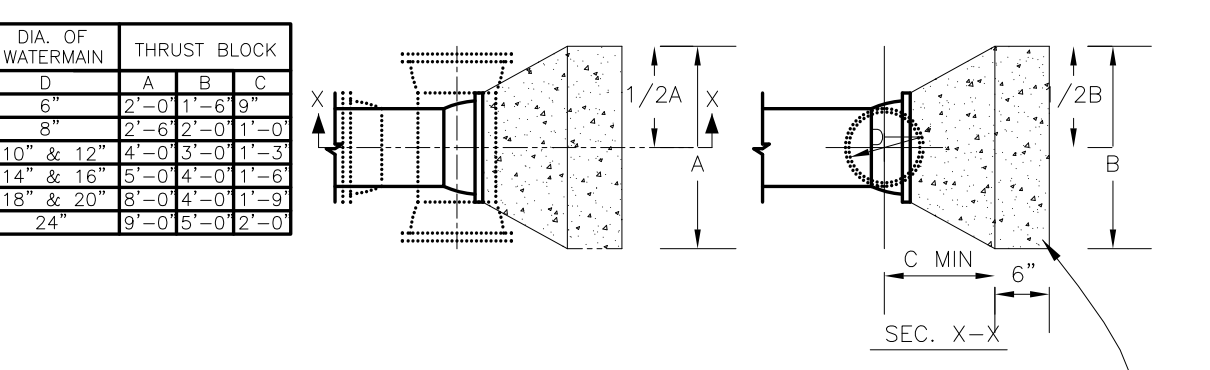
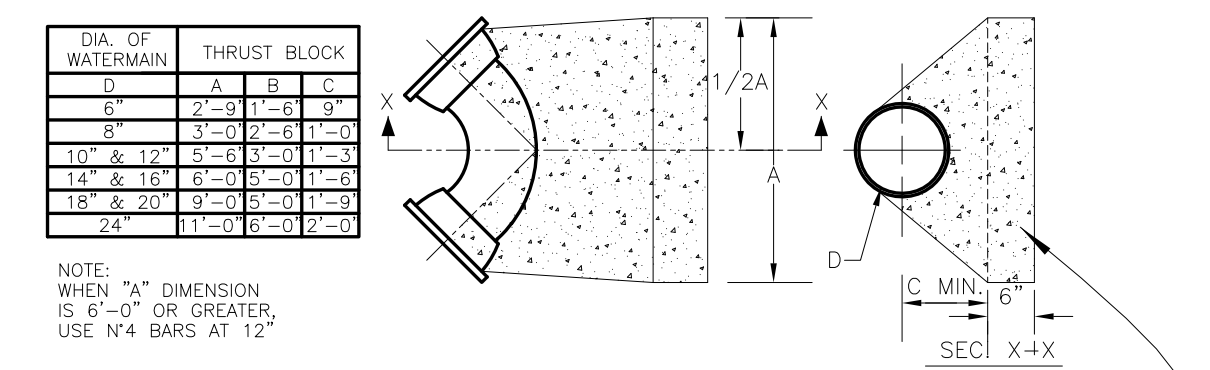
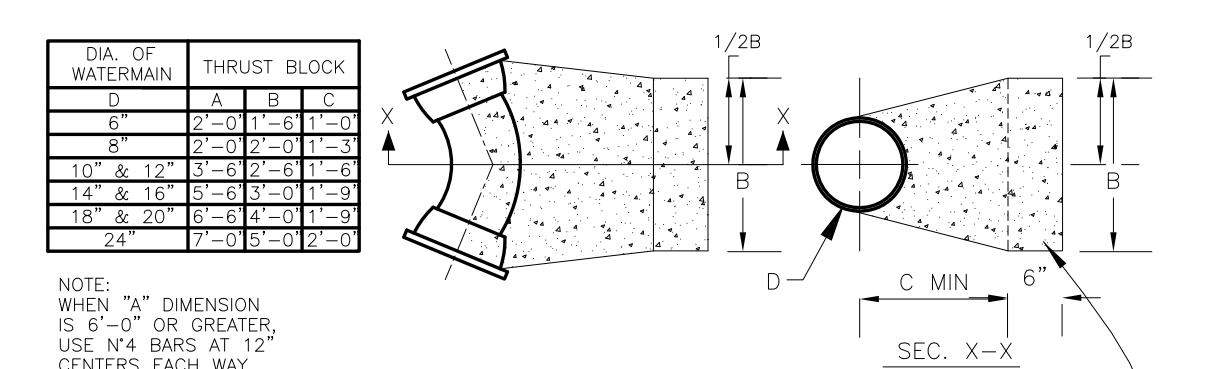
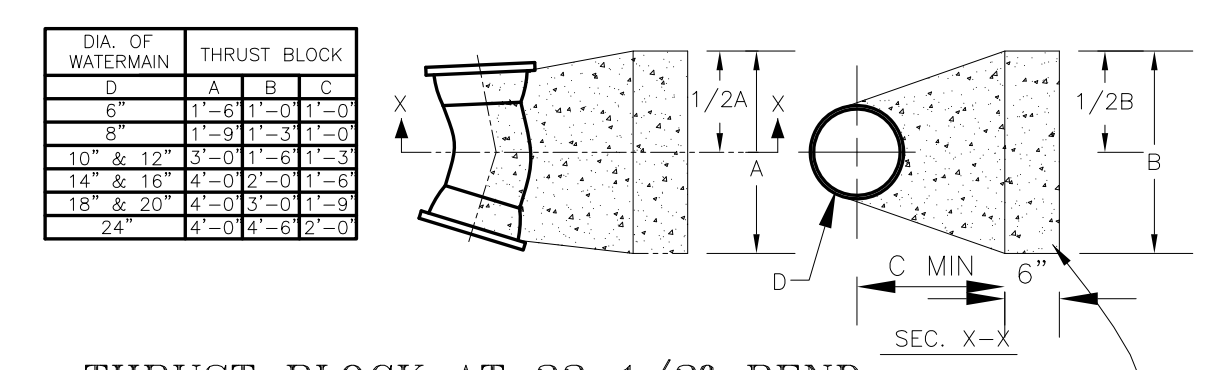
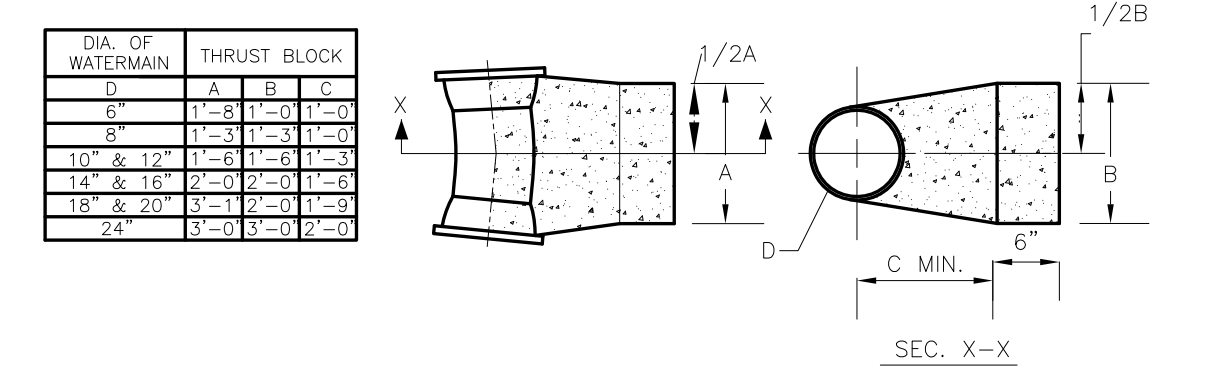

SECTION ON C-C

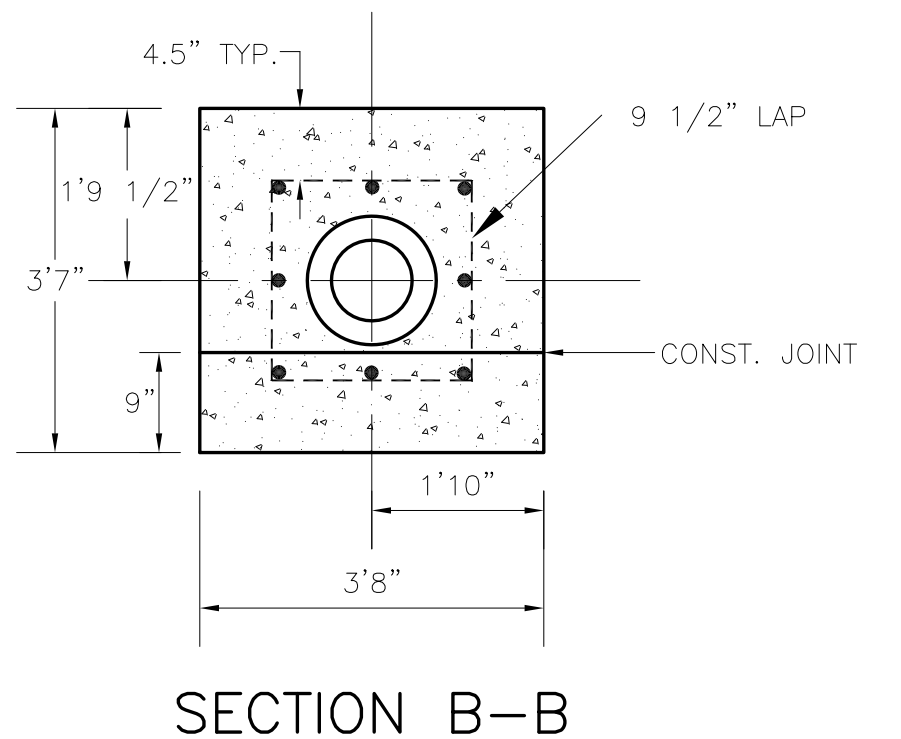

SECTION B-B

LENGTH OF TOP BARS = 7' 1 1/2"
LENGTH OF BOTT BARS = 5' 8 1/2"

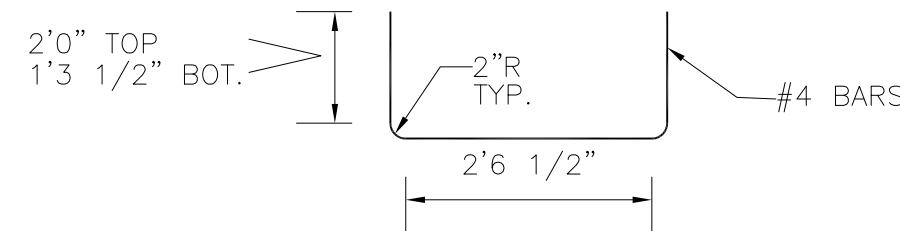

BAR BENDS

16" W.M. ENCASEMENT UNDER DRAINS AND DITCHES

(MINIMUM DEPTH OF BURY FROM BOTTOM OF DRAIN TO TOP OF PIPE "EXCLUDING MUCK" IS 5.5')

NOTE: THESE TABLES ARE BASED ON SOIL BEARING OF 1500 P.S.F. IN MUCK, PEET OR OTHER UNSUITABLE SOILS HAVING A SOIL BEARING LESS THAN 1500 P.S.F., THE CONTRACTOR SHALL PROVIDE SUITABLE ADDITIONAL BLOCKING, ENCASEMENTS OR RESTRAINTS. BLOCKING IN BORE PIT EXCAVATIONS SHALL BE AGAINST UNDISTURBED SOIL OR SHALL BE PROVIDED WITH RESTRAINTS AS REQUIRED.

MINIMUM NOMINAL SIZE OF CASING

Nominal Size of Utility	Cast Iron or Ductile Iron (Inches)
6"	18
8"	20
10"	24
12"	24
14"	30
15"	30
16"	30
18"	30
20"	36
21"	
24"	42
27"	
30"	
36"	
42"	
48"	

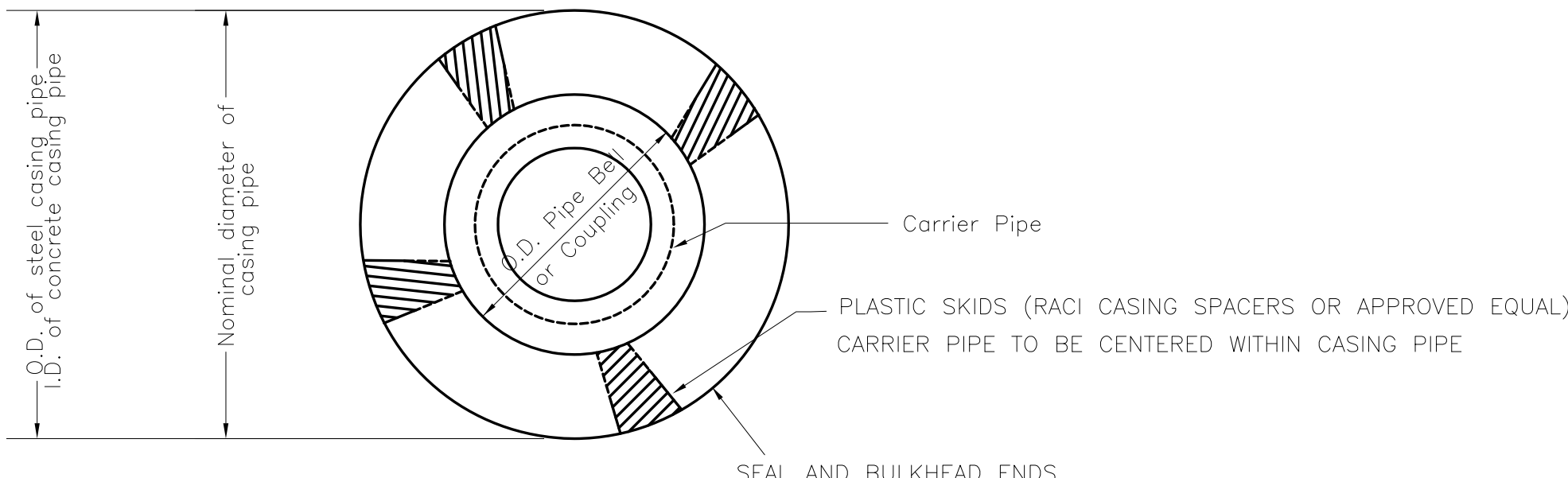

RECOMMENDED CASING SIZE FOR UTILITIES UNDER CITY ROADS

PROJECT NUMBER:
76101
DATE: 04/12/06
SCALE: NTS
DESIGNED BY: RSR
DRAWN BY: BAP/NKA
CHECKED BY:
APPROVED BY:

REVISIONS

MANHOLE STEPS TO BE ON 16 INCH CENTERS. BOTTOM STEP TO BE 24 INCH MAX. ABOVE BOTTOM. STEPS TO BE STEEL REIN- FORCED POLYPROPYLENE ASTM D-2146, TYPE II, GRADE 49108.

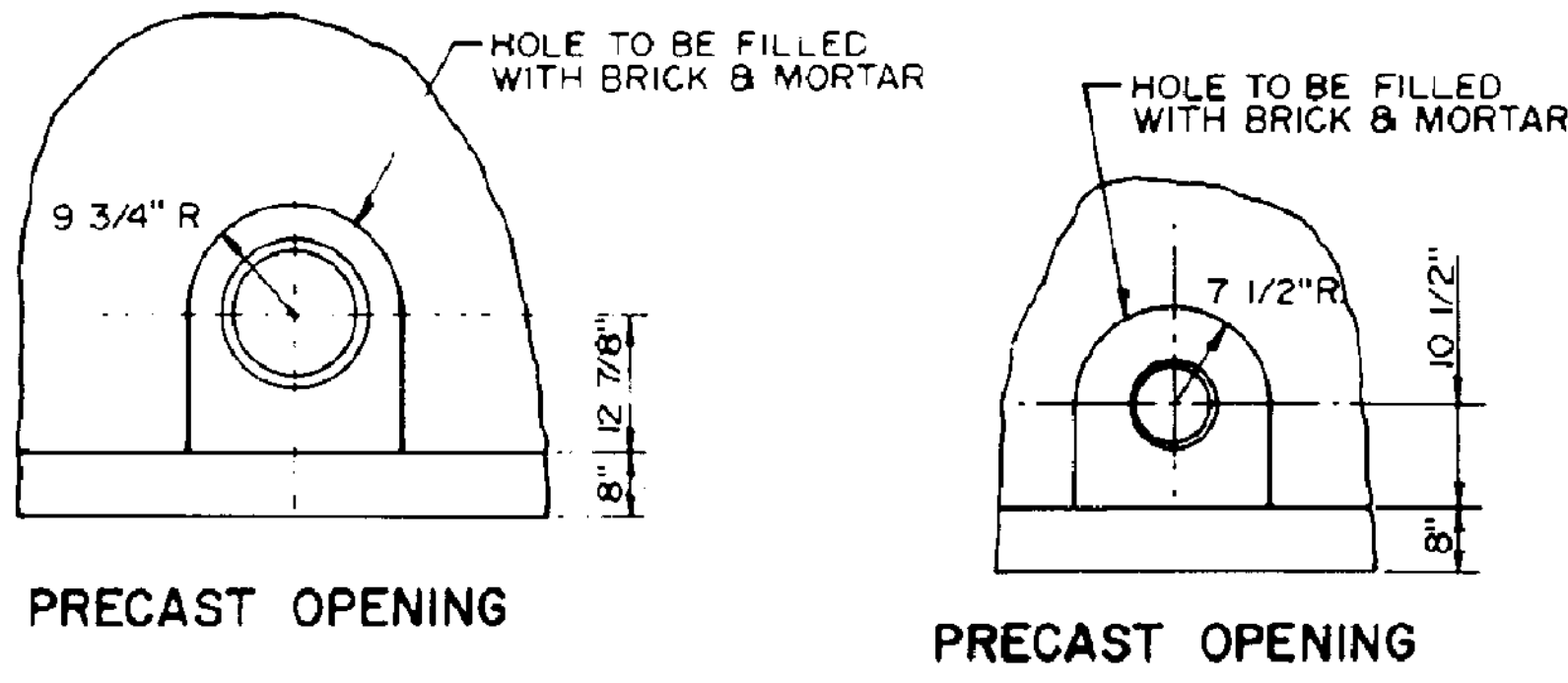
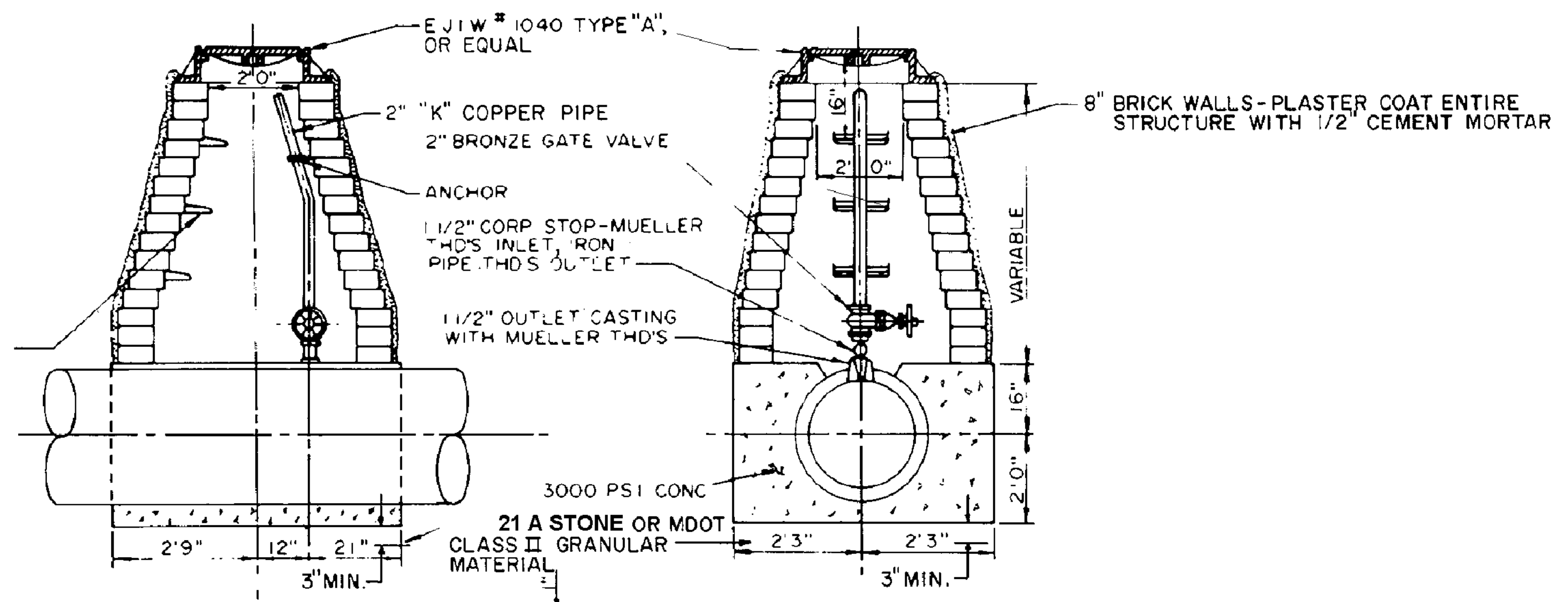

STANDARD AIR RELEASE & WELL FOR 16" & 20" WATER MAIN

USE PRECAST CONCRETE WELL. MANHOLE BLOCK WELL TO BE USED ONLY IN SPECIAL CIRCUMSTANCES WITH THE APPROVAL OF THE CITY.

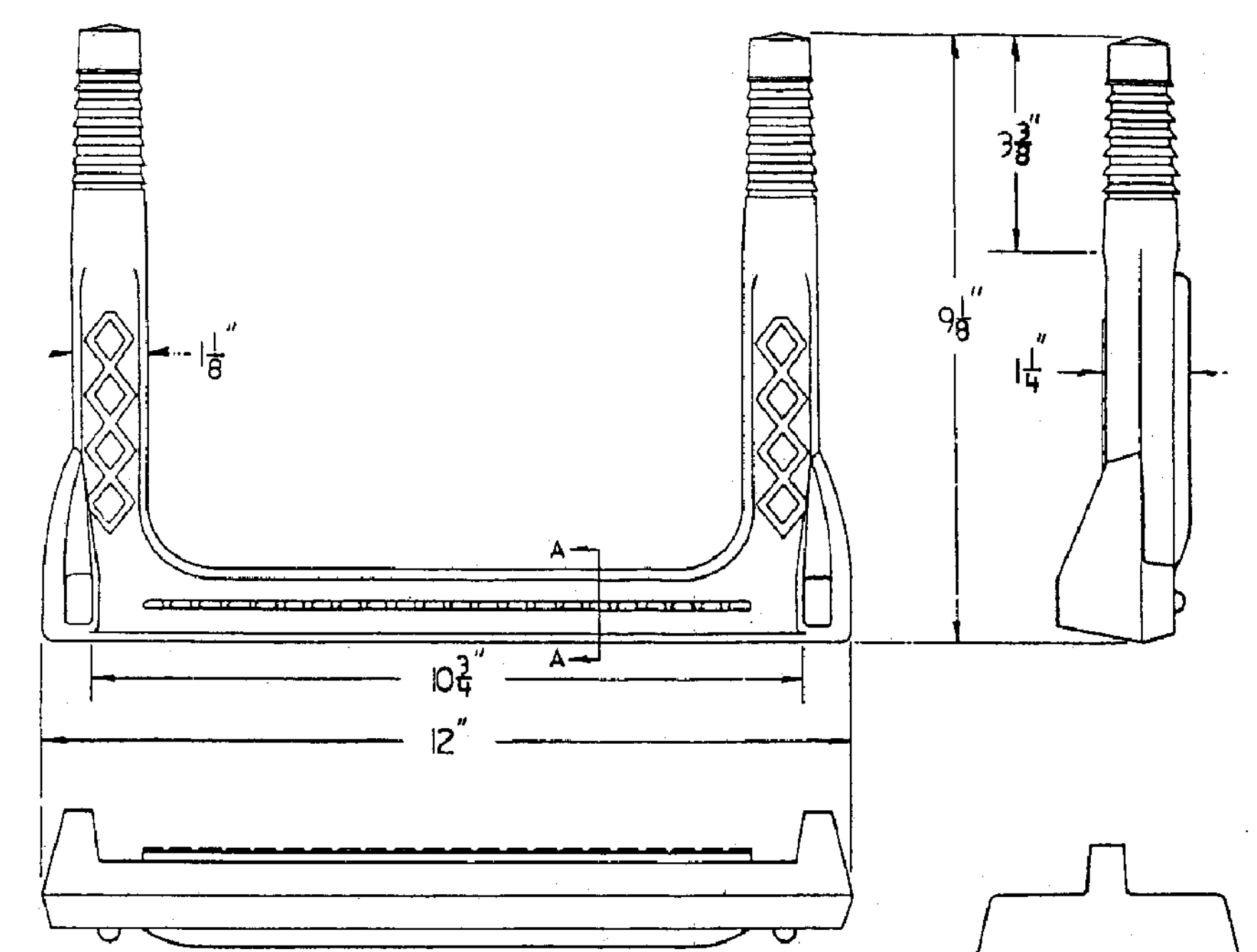
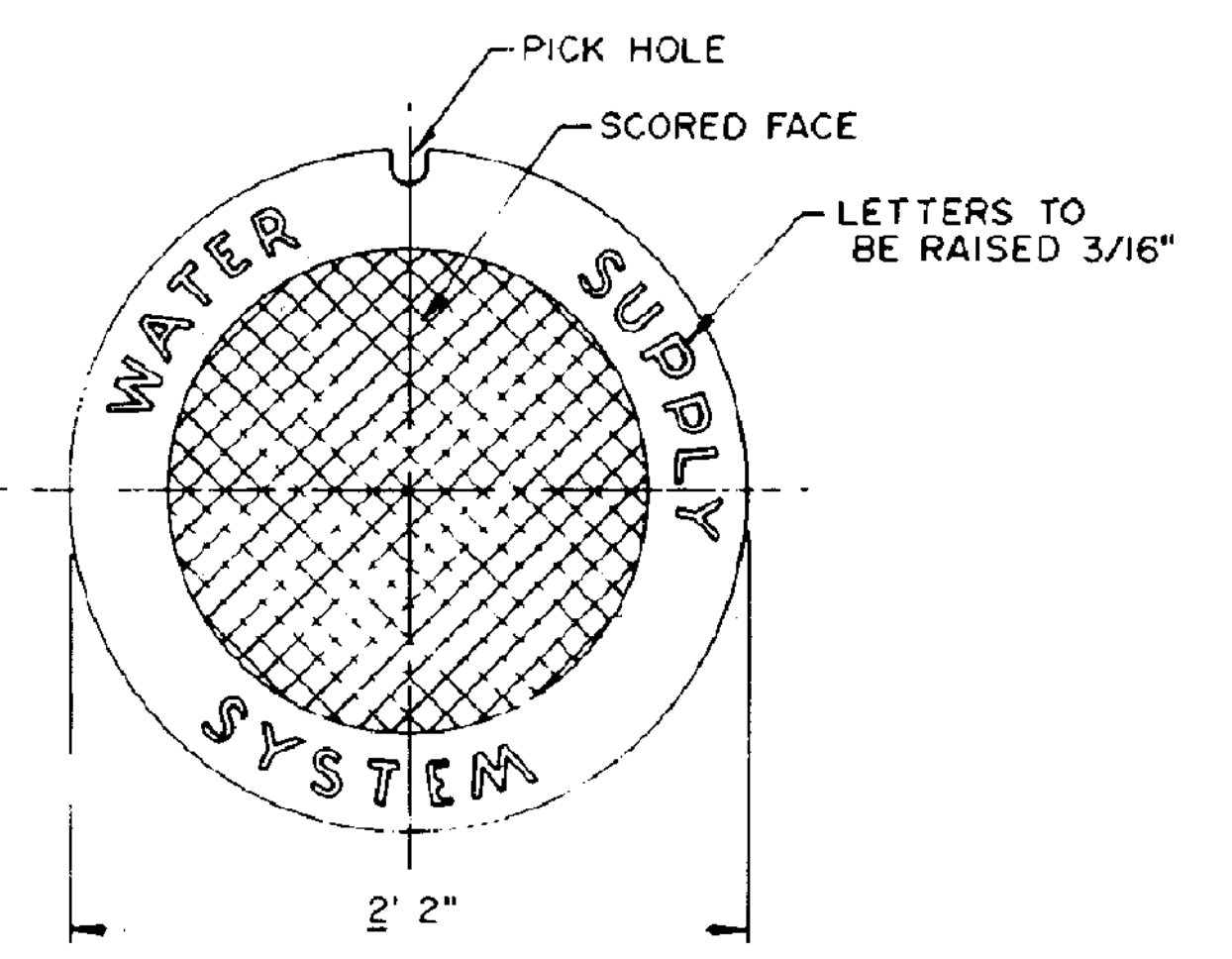
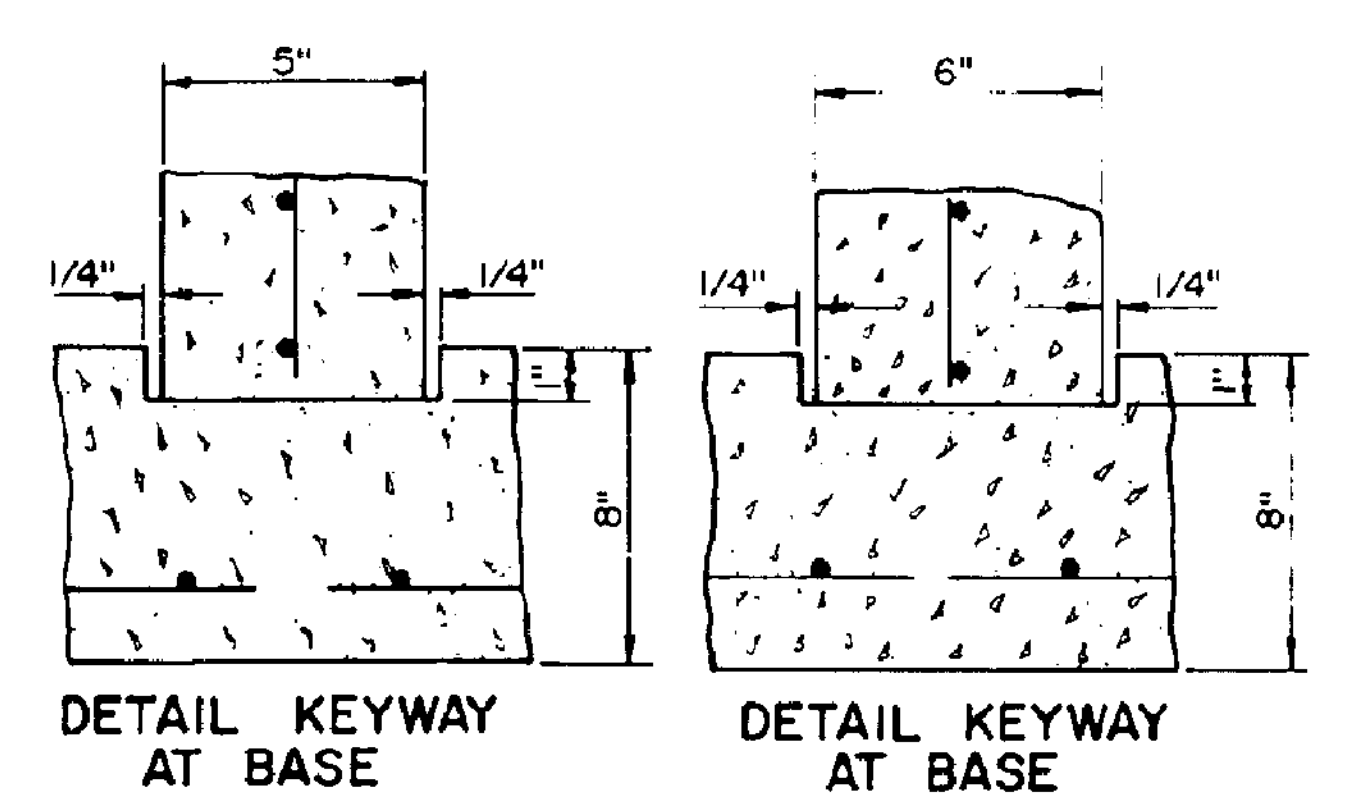

Copolymer Polypropylene Plastic
1/2" GRADE 60 STEEL REINFORCEMENT

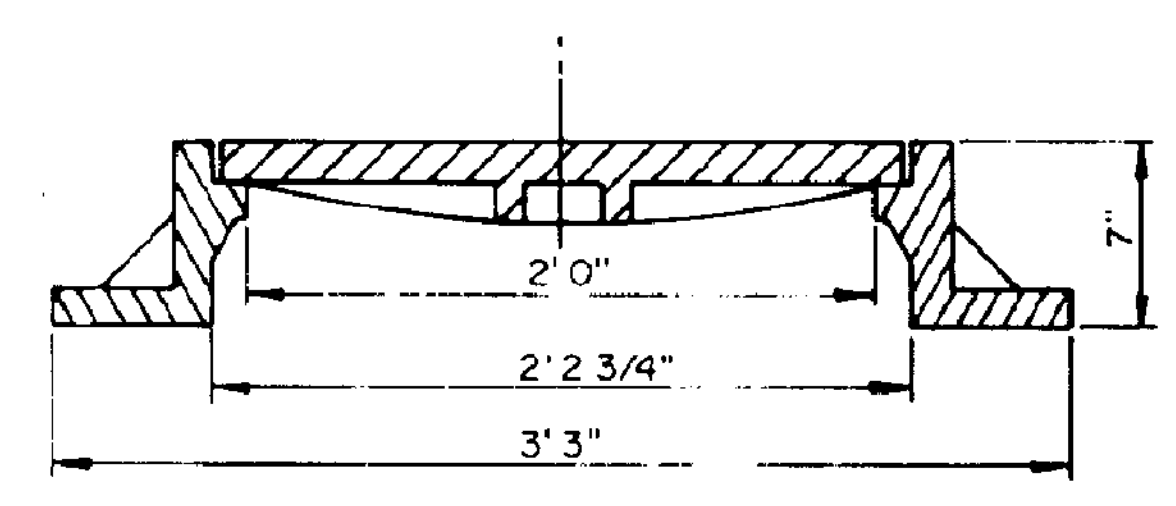
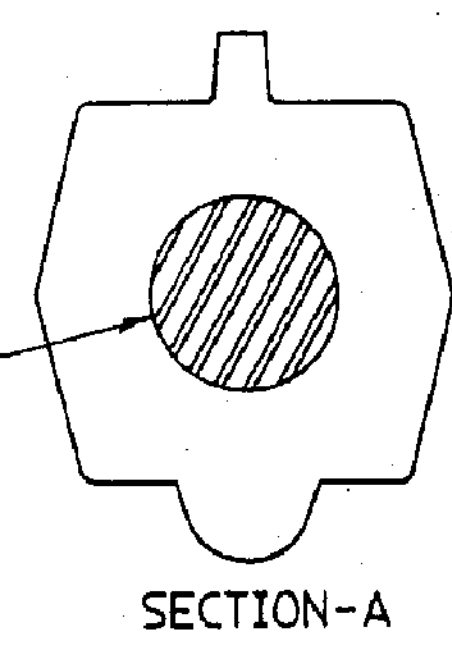

STANDARD FRAME & COVER
E.J.I.W. # 1040, TYPE "A" OR EQUAL

ENGINEERING THE FUTURE
2674 WEST JEFFERSON AVE.
SUITE 200
TRENTON, MI 48183
(734) 692-3300
FAX (734) 692-3203

TITLE STANDARD WATER DETAILS
CITY OF ECORSE
WAYNE COUNTY, MICHIGAN